



**WIT 4-15K-HU Hybrid Inverter
User Manual**

Contents

1	Notes on this manual	1
1.1	Introduction	1
1.2	Target Group	1
1.3	Product Range	1
2	Safety Precautions	2
2.1	Safety Instructions	2
2.2	Symbol Conventions	4
2.3	Label Description	5
3	Product Description	6
3.1	Overview	6
3.2	Battery Switch Status Description	7
3.3	Basic Data	8
3.4	Nameplate	10
3.5	WIT 4-15K-HU Operating Principles	11
3.6	Storing the WIT Inverter	12
3.7	Supported Grid Types	12
3.8	AFCI Function	12
3.8.1	AFCI Functional Description	12
3.8.2	Clearing the Alarm	13
3.9	Anti-PID Function	14
4	Inspection upon delivery	15
5	Installation	17
5.1	Basic Installation Requirements	17
5.2	Installation Environment Requirements	18
5.3	Moving the WIT Inverter	19
5.4	Wall Mount Bracket Installation	20
5.5	Installing the Inverter	21
6	Electrical Connections	23
6.1	Shell Connecting The Ground Cables	30
6.2	Internal Connecting The Ground Cables	31

6.3 Connection on the AC Side	32
6.4 Connection on the PV Side	35
6.5 Connection on the Battery Side	37
6.6 Connecting Communications Cables	39
6.6.1 COM1/COM2 Connection	39
6.6.2 COM3/COM4 Connection (Connecting the signal terminals)	43
6.6.3 USB interface	46
6.7 Post-installation Checks	46
7 Commissioning	48
7.1 Commissioning the WIT Inverter	48
7.1.1 Set the Communication Address	48
7.1.2 Set the Time and Date	48
7.2 Mode of operation	49
7.2.1 Waiting Mode	49
7.2.2 Operating Mode	50
7.2.3 Fault Mode	55
7.2.4 Shutdown Mode	55
7.3 LED and OLED Display Panel	56
8 Monitoring	59
8.1 Remote Monitoring	59
8.1.1 Bluetooth Monitoring on the APP (Shinertools)	59
8.1.2 Remote Monitoring on the APP (ShinePhone)	67
8.1.3 Remote Monitoring on the ShineServer Webpage	91
9 System Maintenance	119
9.1 Routine Maintenance	119
9.1.1 Clean the Chassis	119
9.1.2 Fan Maintenance	119
9.2 Troubleshooting	121
9.2.1 Warning	121
9.2.2 Error	126
10 Product Specifications	132

11 Decommissioning the WIT Inverter	136
12 Warranty	137
12.1 Conditions	137
12.2 Disclaimer	137
13 Contact Us	138

1 Notes on this manual

1.1 Introduction

This manual is intended to introduce the WIT 4-15K-HU Hybrid Inverters manufactured by Shenzhen Growatt New Energy Co., Ltd. (hereinafter referred to as Growatt) in terms of their installation, operation, commissioning, maintenance and troubleshooting. Please read this manual carefully before using the product and keep it in a convenient place for further reference. The content of this manual is continually reviewed and amended, where necessary. Growatt reserves the right to make changes to the material at any time and without notice.

Note:

“WIT” refers to the product name. “4-15K” refers to the power range.

1.2 Target Group

This document is intended for qualified technicians. Only qualified and well-trained technicians are allowed to install and operate the WIT inverter. Should any questions arise during installation, you can visit en.growatt.com to leave a message.

1.3 Product Range

WIT 4-15K-HU (AC 380V/400V) inverters offering seven power options: 4kW, 5kW, 6kW, 8kW, 10kW, 12kW, and 15kW. In total, there are 7 products available in this series. This manual is valid for the following models:

Table 1.1 WIT 4-15K-HU series model introduction

WIT 4K-HU	3-Phase Hybrid Inverter with UPS function
WIT 5K-HU	
WIT 6K-HU	
WIT 8K-HU	
WIT 10K-HU	
WIT 12K-HU	
WIT 15K-HU	

Safety Precautions 2



2.1 Safety Instructions

- 1) Please read this manual carefully before installation. Damages caused by failure to follow the instructions in the manual are beyond the warranty scope.
- 2) Only qualified and trained electrical technicians are allowed to perform operations on the WIT Inverter.
- 3) During installation, please do not touch other parts inside the equipment other than the wiring terminals.
- 4) Ensure that all electrical connections comply with local electrical standards.
- 5) Only designated personnel are permitted to perform maintenance on the inverter.
- 6) Before operating the WIT Inverter in on-grid mode, ensure that you have obtained any permission needed from the local grid operator.



Transportation:

 WARNING	<ul style="list-style-type: none">• Risk of injury when lifting the WIT Inverter, or injury caused by a falling inverter as it is heavy. Please transport and lift the inverter carefully.
---	--



Installation:

 NOTICE	<ul style="list-style-type: none">• Please read this manual carefully before installation. Damages caused by failure to observe instructions specified in this manual are not covered under any warranty.
 DANGER	<ul style="list-style-type: none">• Do not connect any cables before installation.
 WARNING	<ul style="list-style-type: none">• Please observe the installation instructions specified in this manual, including the installation environment and clearance requirements.• Install the WIT Inverter in a dry and well-ventilated location; otherwise, performance de-rate may be initiated due to excessive temperature.• Please read the installation instructions and safety precautions carefully before installation.



Electrical Connections:

 <p>DANGER</p>	<ul style="list-style-type: none">• Before connecting cables, ensure that the DC switches of the WIT Inverter are OFF, and turn off the switch and breaker on the AC side and the battery side. Otherwise, high voltages may cause severe injuries.• It must be operated by qualified and trained electrical technicians. Technicians should observe instructions in this manual and local regulations.• High voltages may cause electric shocks and serious injury. Please do not touch the WIT Inverter in operation.• Do not install the inverter in potentially explosive and flammable atmospheres.
 <p>WARNING</p>	<ul style="list-style-type: none">• Each WIT Inverter must be equipped with an AC circuit breaker. Multiple WIT Inverters cannot connect to the same AC circuit breaker.• Do not connect the load between the WIT Inverter and the circuit breaker.• If the cable is thick, do not shake the cable terminals after tightening them. Otherwise, the loose connection may cause overheating and device damage. Ensure that the terminals are properly connected before starting the WIT Inverter.• Ensure the correct polarity of the terminals before connecting the PV array to the WIT Inverter.





Maintenance and replacement:

 <p>DANGER</p>	<ul style="list-style-type: none">• It must be operated by qualified and trained electrical technicians. Technicians should observe instructions in this manual and local regulations.• After turning off the DC switches and the AC breakers, wait for at least five minutes before performing any operations to avoid risks.• When the OLED screen indicates “PV Isolation low”, do not touch the chassis as a ground fault may have been detected.• Beware of high voltages which may cause electric shocks.
 <p>WARNING</p>	<ul style="list-style-type: none">• To ensure good dissipation, clean the fan regularly.• Do not use the air pump to clean the fan. Otherwise, the fan may be damaged.







Others:

	<ul style="list-style-type: none">• Upon receiving the product, check if the contents are intact and complete. If any damage is found or any component is missing, please contact your distributor.
 WARNING	<ul style="list-style-type: none">• The maximum PV input voltage cannot exceed 1000V. The battery input voltage cannot exceed 60V.• For the WIT Inverter that will not be put into operation in the future, you should properly dispose of them by yourself.

2.2 Symbol Conventions

Symbol	Description
 DANGER	DANGER indicates a hazard with a high level of risk which, if not avoided, will result in death or serious injury.
 WARNING	WARNING indicates a potentially hazardous situation which, if not avoided, could result in death or serious injury.
 CAUTION	CAUTION indicates a hazard with potential risk which, if not avoided, could result in minor or moderate injury.
 NOTICE	NOTICE indicates that under certain circumstances, improper operations could result in property damage.
	Remind operators to check the instructions before installing or operating the WIT Inverter.

2.3 Label Description

Symbol	Name	Meaning
	High voltage	High voltages exist after the WIT Inverter is powered on. Only qualified and trained electrical technicians are allowed to perform operations.
	Burn warning	Do not touch a running inverter because it generates high temperatures on the shell.
	Grounding	Indicates the position for connecting the PE cable.
	Delay discharge mark	Residual voltage exists after the WIT Inverter is powered off. It takes 5 minutes to discharge to the safe voltage.
	Refer to the manual	Remind operators to refer to the manual before installing and operating the WIT Inverter.
	DC	Direct Current.
	AC	Alternating Current.

Product Description 3



NOTICE

The following figure shows the appearance of the WIT 8-15K-HU. The WIT 4-6K-HU has only one MPPT tracker compared to the WIT8-15K-HU, so there is a slight difference in the PV port at the bottom.

3.1 Overview

Front view:

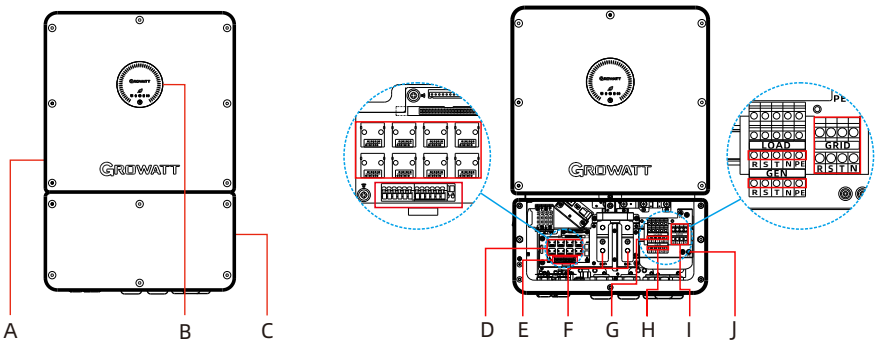

Fig 3.1 Front view

Bottom view:

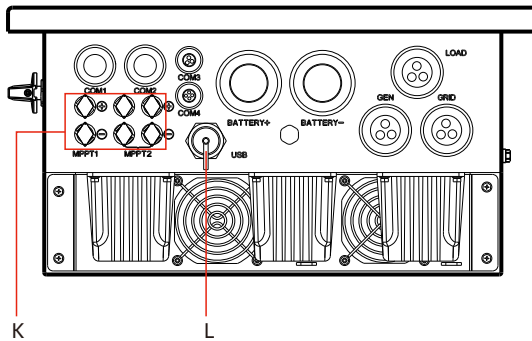

Fig 3.2 Bottom view

Left view:

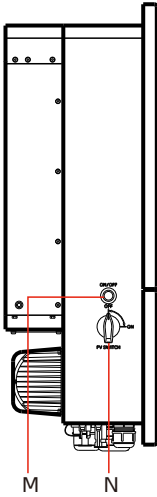

Fig 3.3 Left view

Right view:

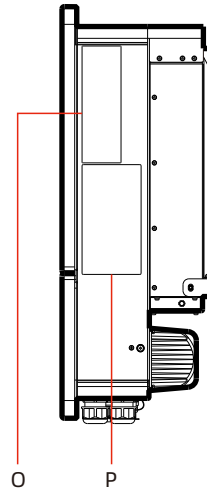

Fig 3.4 Right view

Table 3.1 Component description

No.	descriptions	No.	descriptions
A	Top cover plate	B	Display screen
C	Bottom cover plate	D	Network Port Terminal
E	Signal terminal	F	Battery Terminal Blocks
G	Load wiring terminal	H	Power grid connection terminal
I	Power grid connection terminal	J	PE wiring terminal
K	PV terminal	L	USB interface
M	Battery switch	N	PV Switch
O	Nameplate	P	Indicator description label

3.2 Battery Switch Status Description

When The WIT is connected to the energy storage battery, turn on the switch of the energy storage battery in advance, and press the battery button after 30 seconds, and the button is closed as shown in Fig 3.5 below. When the battery is disabled, close the battery button, as shown in Fig 3.6.

NOTE:

1. Before using the battery to wake up The WIT, make sure the battery button is turned on.
2. Regardless of whether the battery is connected, the battery button should be turned on when The WIT is operating in any mode.

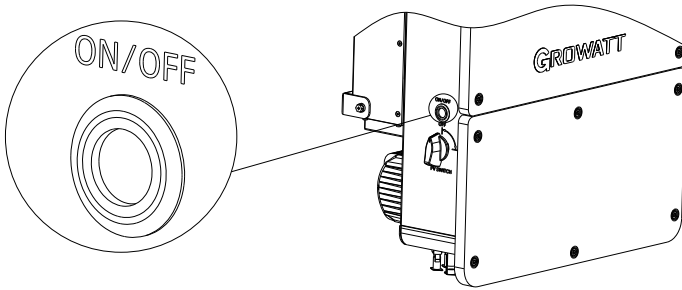

Fig 3.5 Battery Switch-On

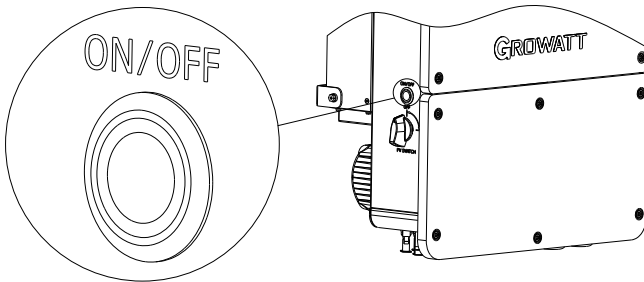

Fig 3.6 Battery Switch-Off

3.3 Basic Data

Table 3.2 Dimensions and weight

	Model	Size (mm)			Weight (kg)
		Height	Width	Depth	
The WIT Inverter without package	WIT 4-15K-HU	698	475	240	43
The WIT Inverter with package	WIT 4-15K-HU	835	590	403	51

unit: mm

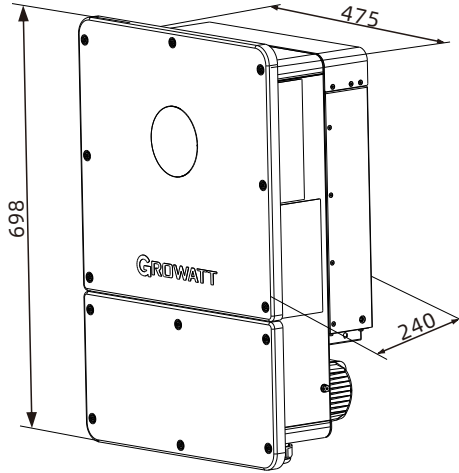

Fig 3.7 Inverter Dimensions

unit: mm

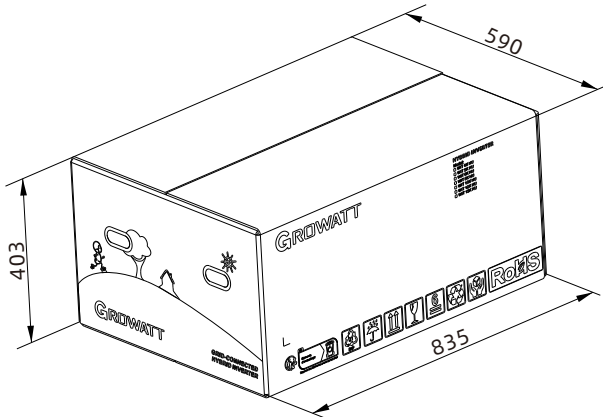

Fig 3.8 Package Dimensions

3.4 Nameplate

The figure below shows the nameplate of WIT 15K-HU as an example. The nameplate figure is for reference only. The actual nameplate prevails. For the specifications, please refer to Section 10 Product Specifications.

GROWATT

Hybrid Inverter
WIT 15K-HU

PV Data

Max. PV voltage	1000d.c.V
PV voltage range	150-850d.c.V
PV Isc	25d.c.A*3
Max. input current	20d.c.A*3

Grid Data

Nominal input/output power	30/15 kW
Max. input/output apparent power	33/16.5 kVA
Nominal voltage	3W/N/PE 380/400 a.c.V
Max. input/output current	50.1/25 a.c.A
Nominal frequency	50/60 Hz
Power factor range	1 leading-1 lagging

GEN Data

Nominal output power	30 kW
Nominal voltage	3W/N/PE 380/400 a.c.V
Nominal frequency	50/60 Hz

Load Data

Nominal AC output power	15 kW
Nominal AC output voltage	230/400 a.c.V
Nominal AC output frequency	50/60 Hz
Power factor range	1 leading-1 lagging

Battery Data

Battery voltage range	40-60 d.c.V
Max. charging and discharging current	290 d.c.A
Type of battery	Lithium-ion/VRLA

General Data

Safety level	Class I
Ingress protection	IP66
Operation ambient temperature	-30°C - +60°C

Integrated with AFCI

Download
Manual

Made in China

Fig 3.9 Nameplate

3.5 WIT 4-15K-HU Operating Principles

- 1) The hybrid inverter receives DC inputs from PV strings which go through the MPPT routes. The DC power is then converted into AC power through the inverter circuit to power the loads and feed power into the grid;
- 2) The PV strings can supply power to charge the battery through the MPPT routes;
- 3) Convert battery power to AC power supplies for the loads and feeding to the grid;
- 4) Charge the battery from the grid through a rectifier circuit;
- 5) Convert the DC power from PV strings and the battery power into AC power through the inverter circuit to power critical loads;
- 6) When the GEN port is connected to the generator and set to the GEN mode, the generator can supply power to the loads or charge the battery;
- 7) When the GEN port is connected to loads and set to "Smart Load" mode; during on-grid operation, it will supply grid power to the loads connected via the GEN port; during off-grid operation, the power supply to smart loads will be cut off when the battery SOC is below 50%.
- 8) When the GEN port is connected to the PV inverter and set to "AC Couple" mode, during on-grid operation, the PV inverter will be connected to the grid and output power; during off-grid operation, the PV inverter will remain connected and generating power together with the WIT inverter.

NOTE: WIT 4-15K-HU models have 2 MPPT routes.

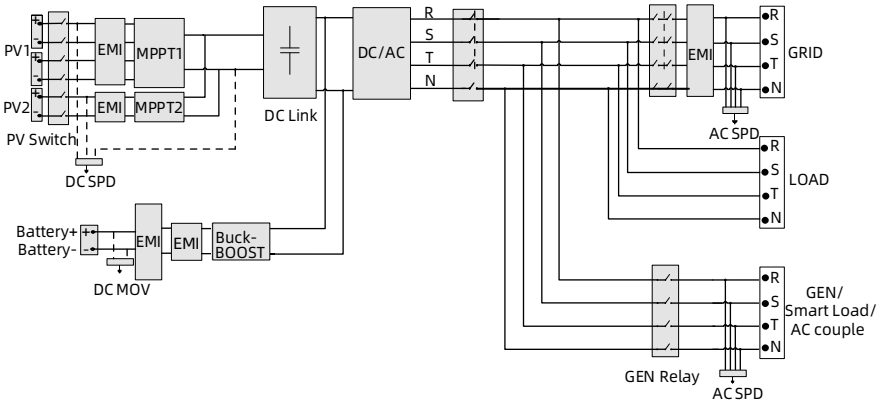

Fig 3.10 WIT 4-15K-HU Grid-connected conceptual diagram

3.6 Storing the WIT Inverter

- 1> Put the WIT Inverter in the original package and place it in a dry and well-ventilated place.
- 2> Keep the storage temperature from -40°C to $+70^{\circ}\text{C}$ and the humidity from 0%-95% RH.
- 3> A maximum of three WIT Inverters can be stacked. Do not stack the inverters without package.
- 4> If the WIT Inverter has been long-term stored, inspections and tests should be conducted by qualified personnel before installation.



Wrong time and date may occur if the WIT Inverter has been stored for over one month. Fix the time and date before connecting the inverter to the grid. For details, see Fig 7.1 Commissioning the WIT Inverter.

3.7 Supported Grid Types

Grid connection modes for WIT 4-15K-HU Hybrid Inverters are shown in Fig 3.11.

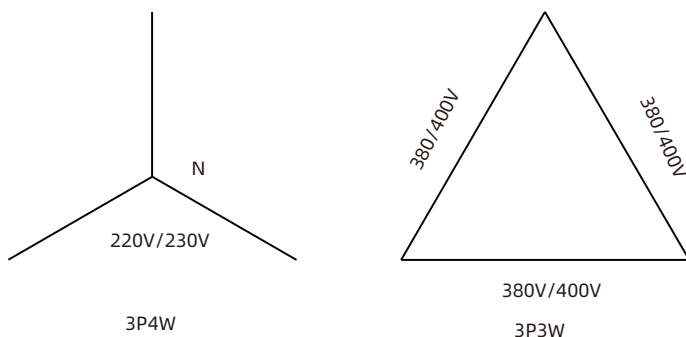

Fig 3.11 380V / 400V system (type Y/Δ)

3.8 AFCI Function

3.8.1 AFCI function Description

An AFCI, or Arc-Fault Circuit Interrupter, is a solution designed to detect and mitigate the risk of electrical arcing in a photovoltaic (PV) system, supported by intelligent arc detection algorithm. Arcing can occur when there is a high voltage breakdown in the electrical insulation or when conductive materials come into contact with each other. This can pose a fire hazard and damage the system components. The AFCI continuously monitors the system for potential arc faults and, if detected, interrupts the circuit to prevent a fire or other damage. AFCIs are required by the National Electrical Code (NEC) in certain parts of a PV system, such as the DC side of the inverter, to improve safety and reduce the risk of fires.

NOTE:

1. The AFCI Function of the WIT Inverter is disabled by default. If you want to enable the AFCI, please contact Growatt support.
2. Do not connect the Maximum Power Point Trackers (MPPTs) on the DC side in parallel as it might trigger the AFCI mistakenly.

3.8.2 Clearing the Alarm

In the event that the WIT Inverter reports “AFCI Fault” and the PV indicator turns red, an arc fault might have been detected. Please perform the following steps to clear the alarm.

Step 1: Disconnect the WIT inverter from all power sources. Turn off the battery switch and the AC output circuit breaker, then turn the DC switches to the OFF position. Wait until the error message disappears.

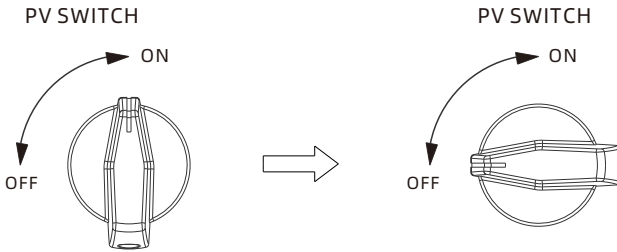

Fig 3.12

Step 2: Troubleshooting. Check if the open-circuit of all PV strings are within the permissible range.

Step 3: After the fault is cleared, restart the inverter. Turn on the battery switch and the AC breaker, and turn the DC switch to the ON position. Wait until the system is working properly.

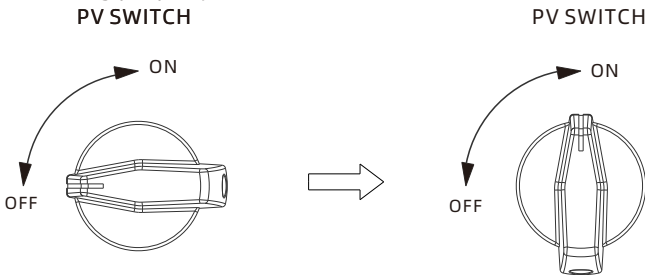

Fig 3.13

If the WIT Inverter passes the AFCI self-test, it will work in the normal mode and the PV indicator will be green. If it fails, the inverter will report "Error 425". In this case, please reboot the system and perform Step 1 to Step 3. If it failed again, please disconnect all power sources and contact Growatt support.

3.9 Anti-PID Function

PID (Potential Induced Degradation) typically occurs in PV systems where there is a voltage potential between the solar cells and the grounded frame or other conductive elements of the system. This potential difference, combined with high humidity and temperature, can lead to leakage currents that degrade the performance of the solar modules over time. The Anti-PID function integrated in Growatt inverters can effectively reverse the PID effect by applying DC voltage to the PV modules during nighttime, enhancing solar energy harvest and performance.

4 Inspection upon delivery

Unpacking and inspection

- 1> Before unpacking the WIT Inverter, check the shipping box for any externally visible damage. If any damage is found, contact the shipping company as soon as possible.
- 2> After unpacking the WIT Inverter, check if the scope of delivery is intact and complete. If any damage is found or any component is missing, contact your distributor.

Check the following items:

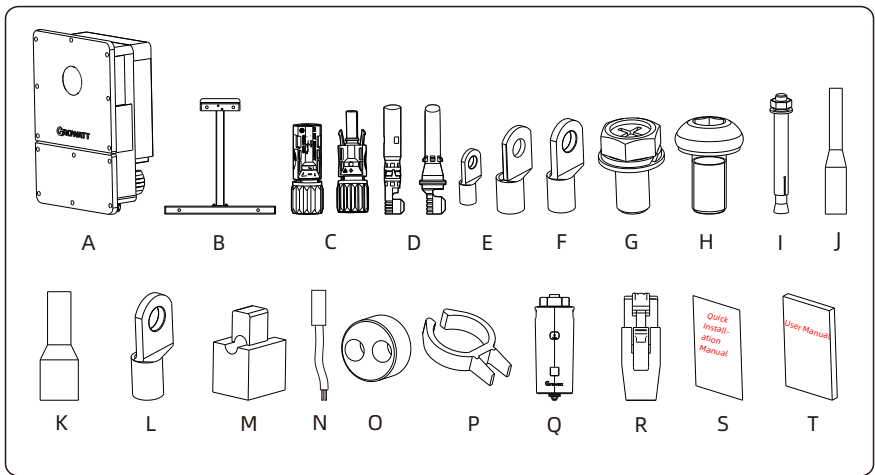

Fig 4 WIT 4-15K-HU Attachment

Table 4.1 Packing list

No.	Description	Quantity	No.	Description	Quantity
A	The WIT Inverter	1	K	AC Side Rail Crimp Terminals	14
B	Wall mount kit	1	L	RNB8-4S Terminal	1
C	PV+(-) connector	3/3	M	CT (100A/40mA)	3
D	PV+(-) metal contact	3/3	N	External lead-acid battery NTC cable	1
E	Battery terminal SC50-8/SC120-8	4/2	O	Plug/2-Φ12	2
F	SC4-6 terminal	1	P	PV connector disconnect tool	1
G	M8*16 screw	4	Q	ShineWiLan-X2	1
H	M6*16 screw	2	R	Rj45	8
I	M8*80 screw	4	S	user manual	1
J	Communication Crimp Terminal	14	T	Quick Guide	1

NOTE:

1. Sturdy and durable though the packing carton is, please carry and handle it with caution.
2. When connecting 2-channel battery on the battery input side, use the attached rubber plug to ensure reliable sealing;
3. Normal use of the machine accessory CT for backflow prevention and other energy flow control, customers do not need to purchase a separate meter and CT, just connect the CT's secondary side wiring to the corresponding terminals of the WIT 4-15K-HU machine.

5 Installation

5.1 Basic Installation Requirements

- A. The installation location must be suitable for WIT's weight for a long period time. (Refer to Table 3.2 for the weight of the WIT Inverter).
- B. Ensure that the installation position is suitable for the dimensions of the WIT Inverter.
- C. Do not install the WIT Inverter in areas with flammable or non heat-resistant materials.
- D. The WIT Inverter is protected to IP66 and can be installed indoors or outdoors.
- E. Do not expose the WIT Inverter to direct sunlight. Otherwise, excessive temperature may lead to power reduction.
- F. Keep the humidity at 0% to 95% RH.
- G. Keep the ambient temperature at -30°C to 60°C .
- H. The WIT inverter can be installed vertically or backward tilted. Please refer to the figures below:

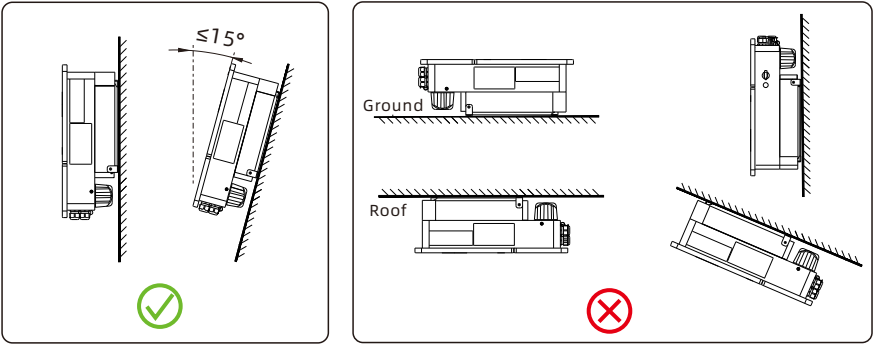

Fig 5.1

- I. Reserve enough clearance around the WIT Inverter to ensure sufficient space for heat dissipation and operation. Leave a clearance of 0.6 m on both sides, approximate 0.6 m above and below the WIT Inverter, and 1 m in front of the inverter.

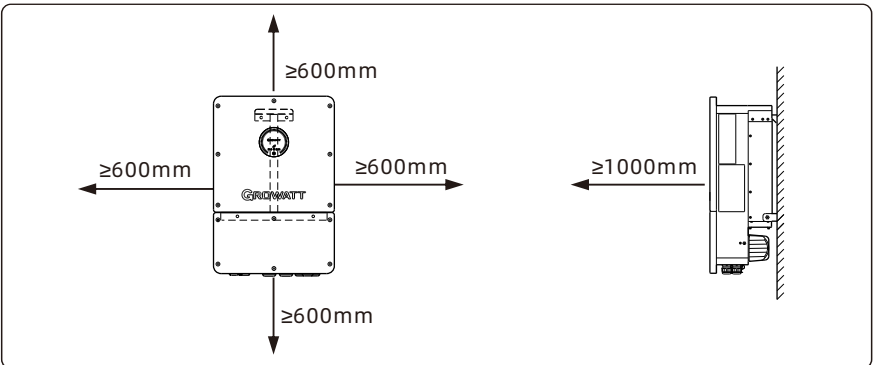

Fig 5.2

- J. Keep the WIT Inverter away from strong interference sources.
- K. Ensure that the WIT Inverter is not accessible to children.

5.2 Installation Environment Requirements

A. Though the WIT Inverter is protected to IP66, do not expose it to direct sunlight, rain and snow. Please refer to the figures below:



Fig 5.3

B. To reduce the de-rate performance of the inverter and extend inverter's life span, we strongly recommend you install an awning. For the distance between an awning and inverter, please refer to following figure:

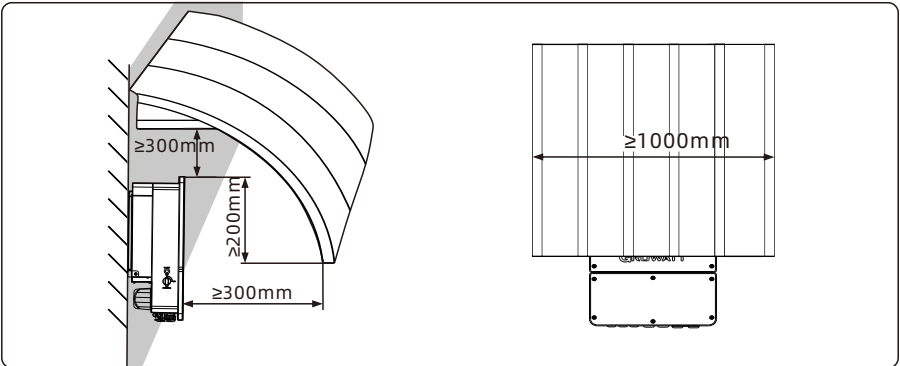
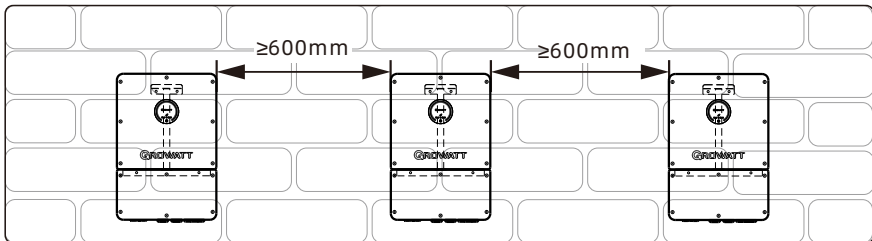

Fig 5.4

C. When you install multiple WIT inverters on one surface, inverters should be installed as following drawing. (Choose one of the two options below).



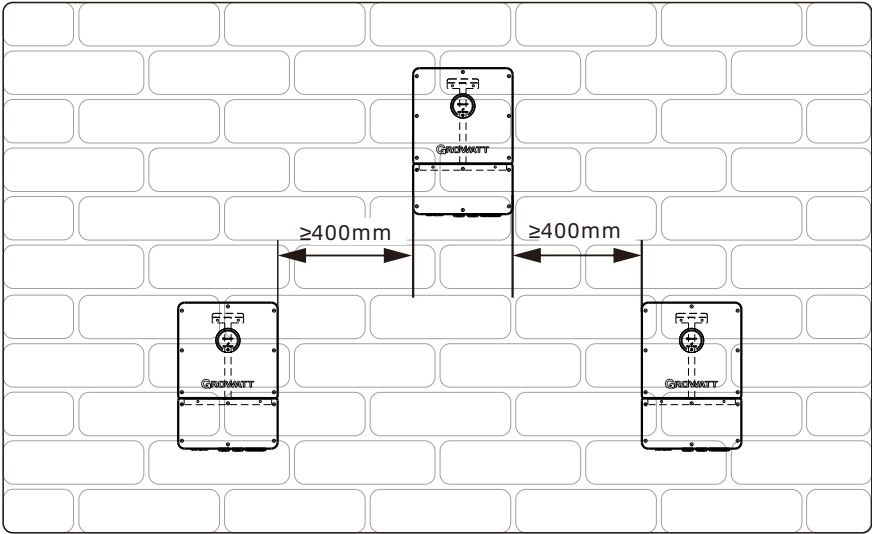

Fig 5.5

D. Do not place the WIT Inverter in an enclosed and narrow space for operation.

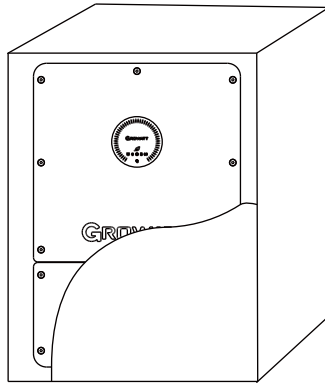

Fig 5.6

5.3 Moving the WIT Inverter



CAUTION

- The inverter is heavy, please move it with care and keep balance to avoid personnel injury.
- Do not place the inverter with its wiring and signal terminals at the bottom contacting with floor or any other object because the terminals are not designed to support the weight of inverter.

- 1>As shown in Fig 5.7, two persons are required to lift the inverter out of the package and transport it to the installation position.
- 2>When you are moving the inverter, please keep the balance.

Note: There will be front and bottom mark on the package.

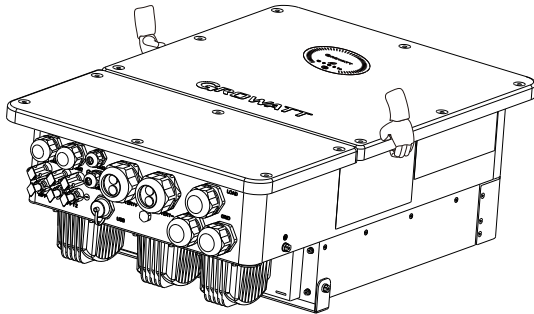

Fig 5.7

5.4 Wall Mount Bracket Installation

Before installing the inverter, you need install the wall mount bracket so that the inverter can be securely mounted on the wall.

Wall mount bracket (unit: mm):

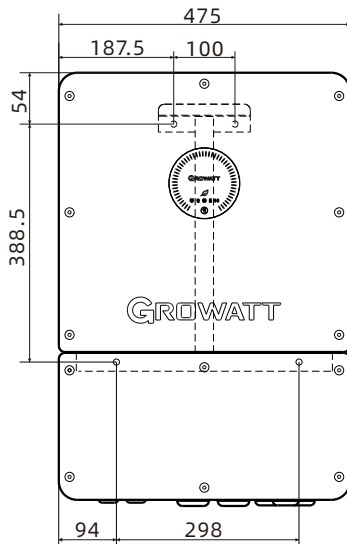

Fig 5.8

STEP 1: Use the wall mount plate as a template, drill holes into the wall and insert the expansion bolts as Fig 5.9 show.

STEP 2: Tighten the bolts to attach the wall mount bracket onto the wall securely as illustrated below.

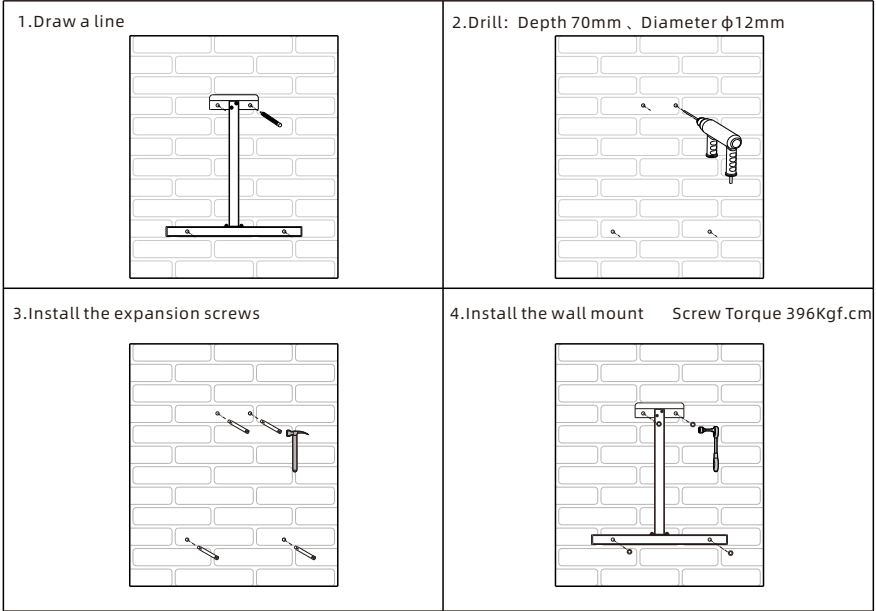

Fig 5.9

Note:

- 1> The wall where the expansion bolts are installed should be a solid concrete or brick wall with a thickness of at least 100 mm.
- 2> Ensure that the bracket has been firmly installed before mounting the inverter onto it.

5.5 Installing the Inverter

After verifying that the wall mount bracket has been firmly installed on the wall, mount the inverter onto the bracket.

- 1> The installer uses both hands to lift the machine as shown in Fig 5.10 below.
- 2> Hang the inverter onto the wall mount bracket and install the bolts. Please keep balance when moving the inverter.
- 3> Check if the inverter has been properly mounted and tighten all screws.

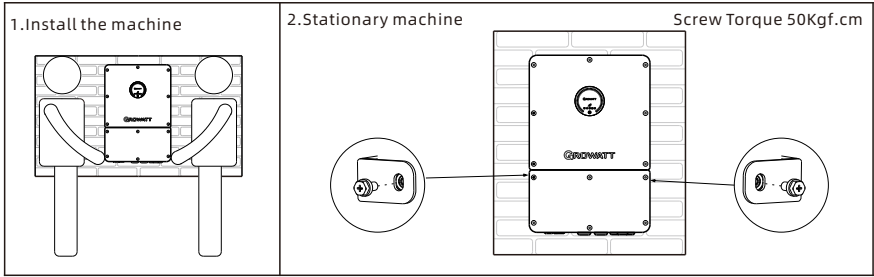



Fig 5.10 Wall-mounted installation

 <p>NOTICE</p>	<p>Ensure that the wall meets the load-bearing requirements of the equipment. For details about the weight, see Table 3.2.</p>
--	--

6 Electrical Connection

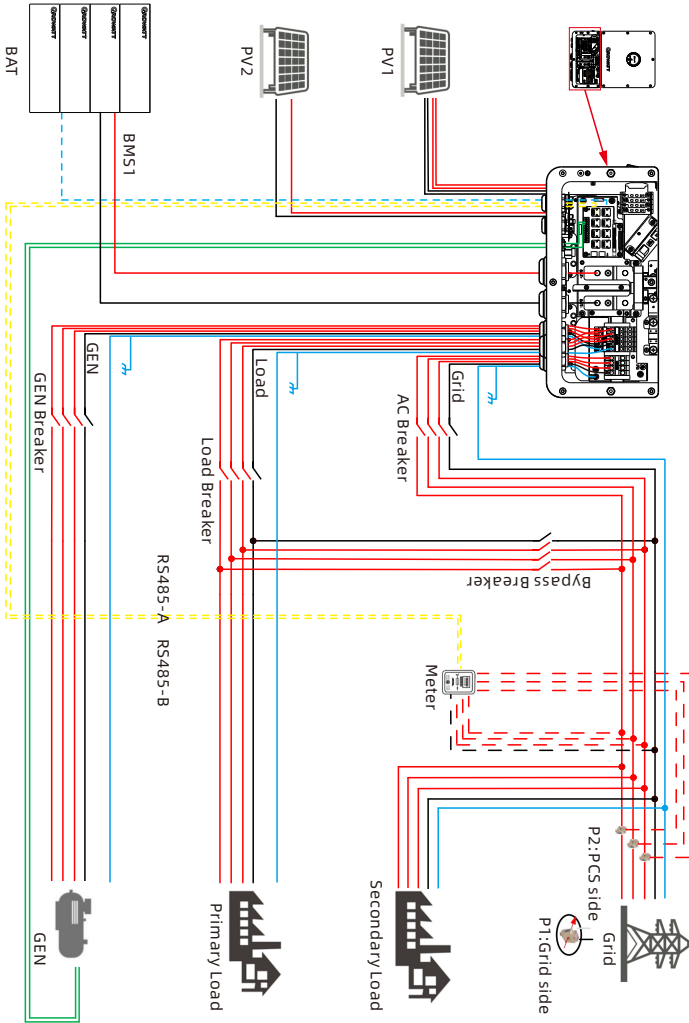

Fig 6.1 Wiring diagram of the system with a single WIT 15K-HU inverter (Gen mode)

NOTE:

1. Connect the signal wires of the generator and the meter to the relevant positions of the CN10 terminal according to Table 6.6.
2. Set the parameters on the client. Take ShinePhone as an example: Tap Control > Off grid parameter settings > Related settings for grid connection and off grid > Grid connected / off grid setup > Generator; As shown in Fig 8.39; (2) Tap Control > Advanced > Microgrid system > Types of Access for GEN Port Devices > Generator and > Generator Enable > Enable, And set other parameters as required.

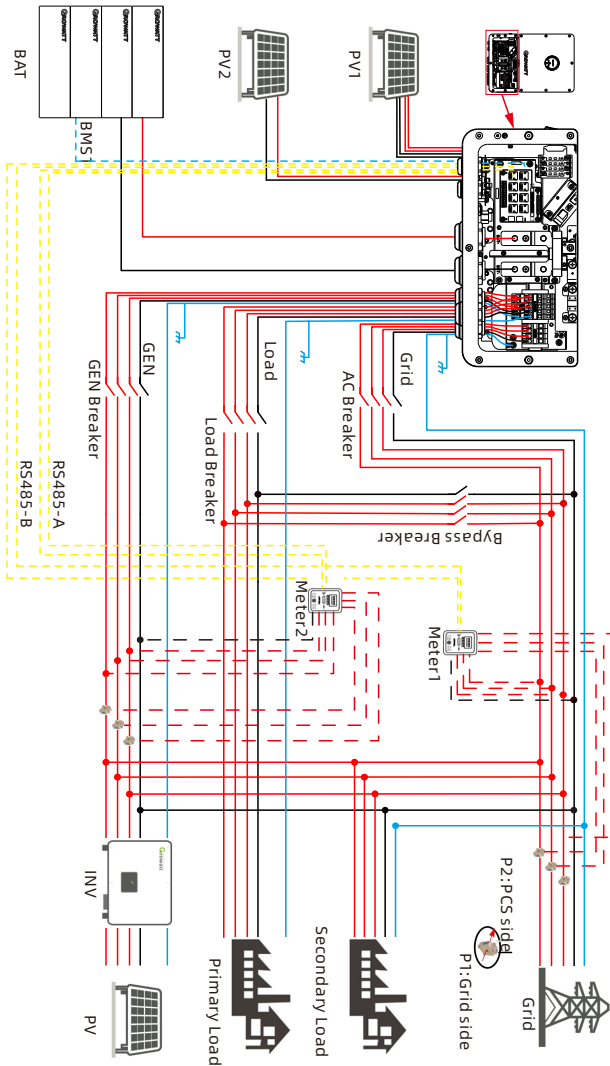

Fig 6.2 Wiring diagram of the system with a single WIT 15K-HU inverter and two meters (AC couple mode)

NOTE:

1. Connect the signal wires of the meter to the relevant positions of the CN10 terminal according to Table 6.6.
2. Perform related Settings on the client. Take ShinePhone as an example: Tap Control > Advanced > Microgrid system> Types of Access for GEN Port Devices>Inverter and >AC Couple Enable> Enable, And set other parameters as required.

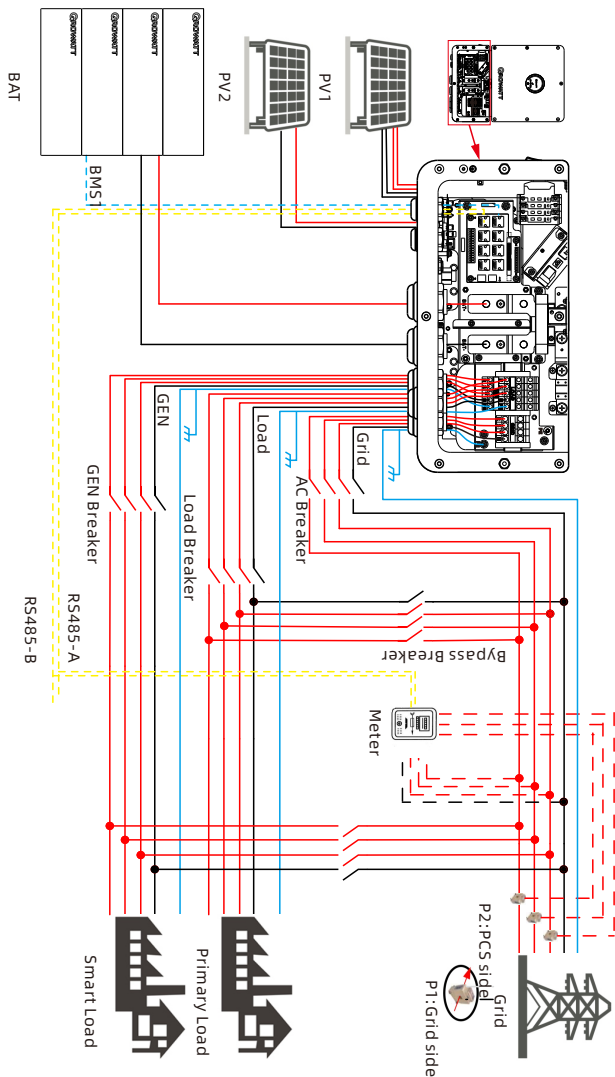

Fig 6.3 Wiring diagram of the system with single WIT 15K-HU inverters in smart load mode

NOTE:

1. Connect the signal wires of the meter to the relevant positions of the CN10 terminal according to Table 6.6.
2. Perform related Settings on the client. Take ShinePhone as an example: Tap Control > Advanced > Microgrid system > Types of Access for GEN Port Devices > Smart Load.

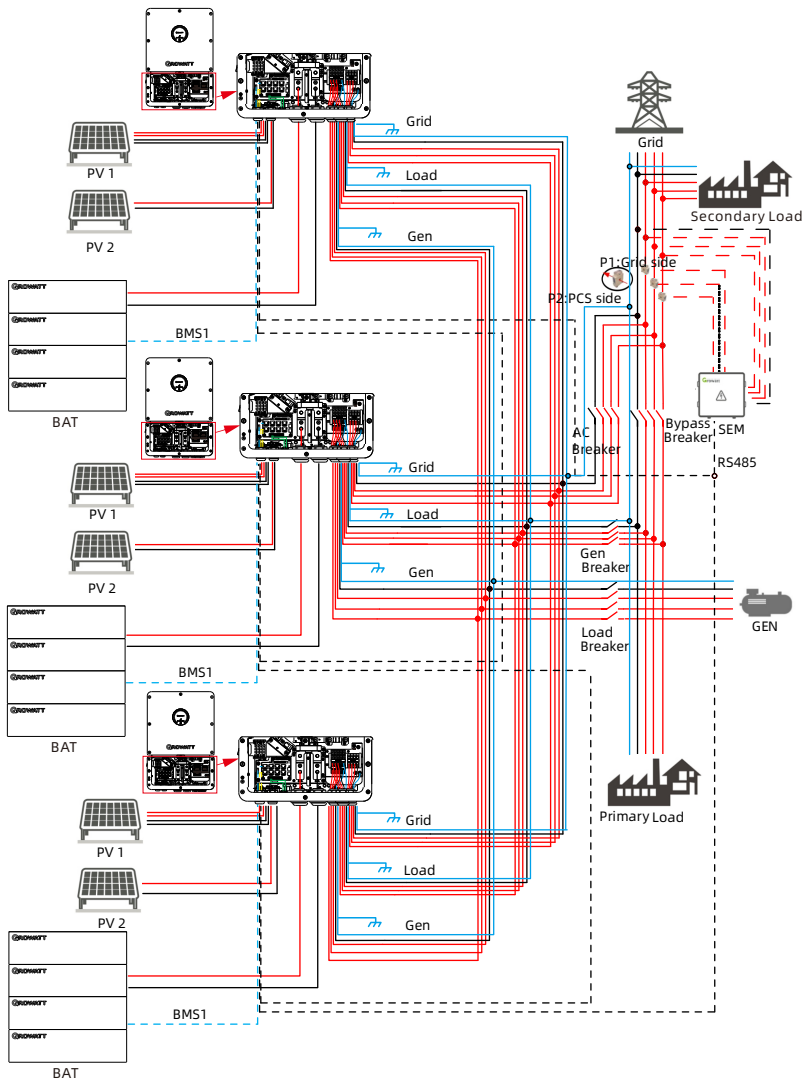
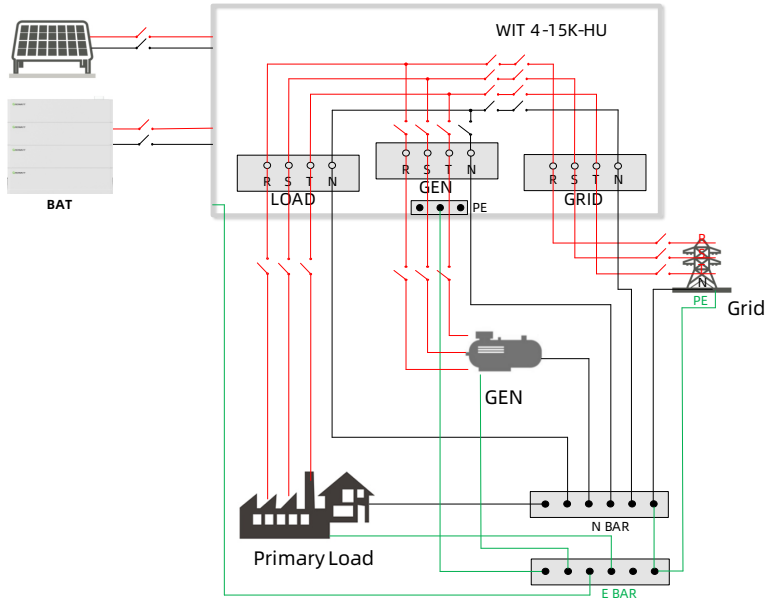

Fig 6.4 Wiring diagram of the system with three WIT 15K-HU inverters connected in parallel

NOTE:

1. Perform related Settings on the client. Take ShinePhone as an example: Tap Control > Parallel parameter setting > Parallel enable > Enable.
2. The wiring methods for different regions are shown in Fig 6.5 below, please select the wiring method according to the local safety regulations.



(a) AU/NZ area wiring

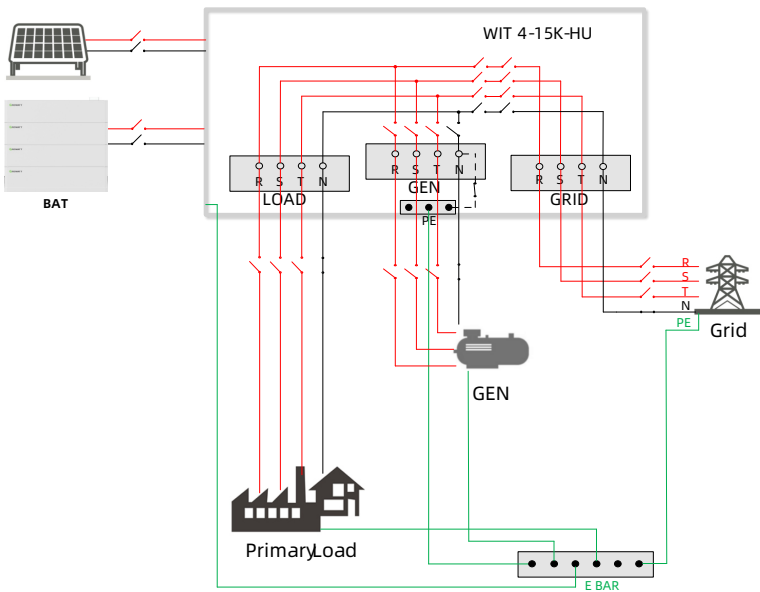

(b) Other area wiring

Fig 6.5 N-PE Wiring in Different Areas

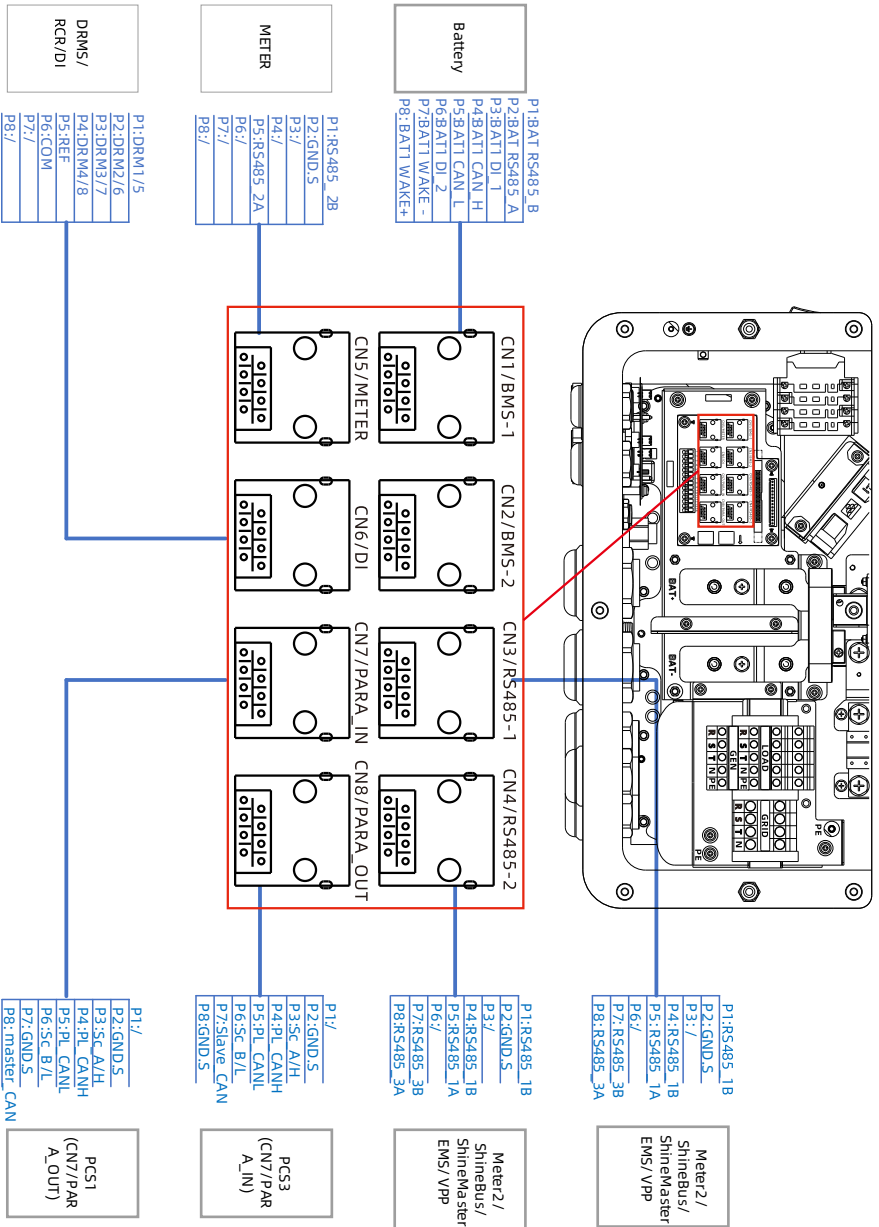

Fig 6.6 Communication network port Detailed information

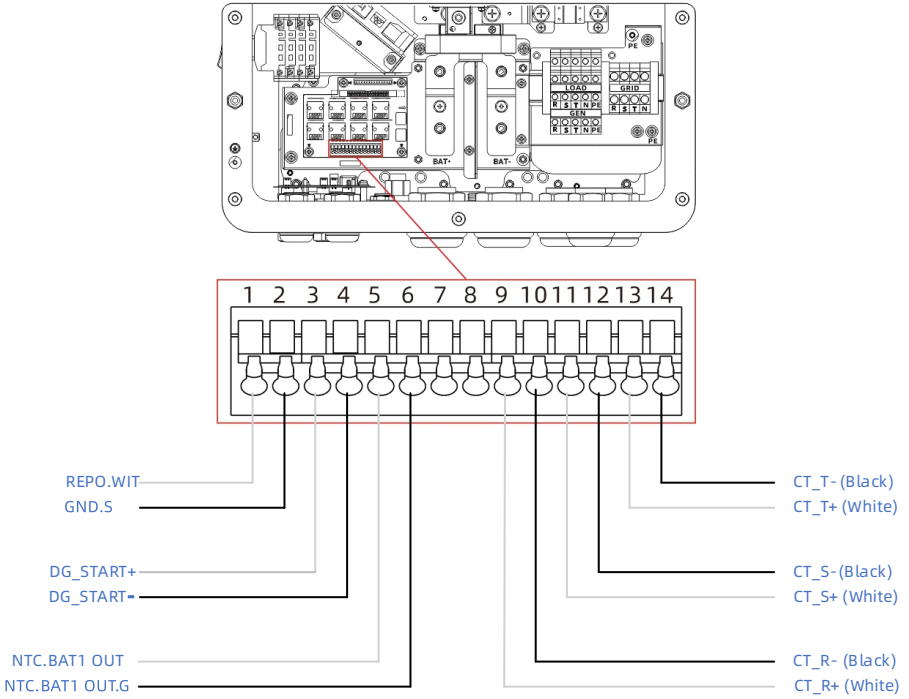

Fig 6.7 Signal terminal

6.1 Shell Connecting The Ground Cables

- 1) It is essential to connect the ground cable to the WIT inverter before connecting other cables to prevent personal injury or device damage.
- 2) All non-current-carrying metal parts and the enclosures of the devices of the energy storage system, including the rack and the enclosures of the combing box, the distribution panel, the inverter and the battery should be properly grounded.
- 3) For a single WIT inverter, connect a ground cable to the ground point on the chassis shell. For a system with multiple WIT inverters connected in parallel ensure that the enclosures of the WIT Inverters, the metal racks of the modules and the batteries should be connected to the same area to achieve equipotential bonding.
- 4) The position of the ground points of the WIT 4-15K-HU Hybrid Inverter is shown in Fig 6.6.

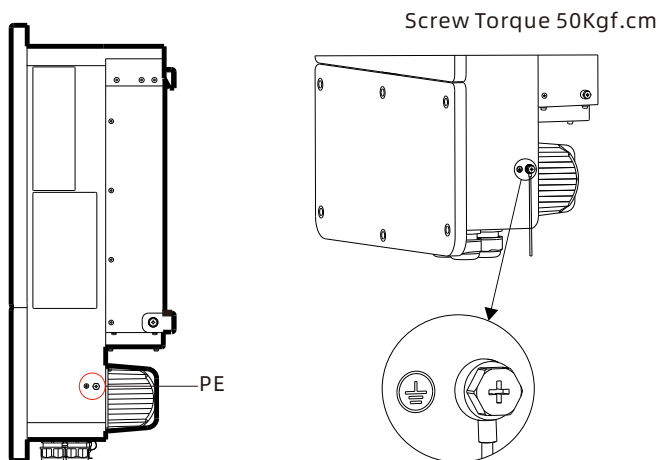

Fig 6.8 Protective earthing position

Attention:

1. Keep the lightning protection grounding at the greatest possible distance from the protective grounding.
2. Protect the terminals of the ground cables against rain and do not expose them to open air.
3. Tighten the screws to a torque of 50 kgf·cm.

6.2 Internal Connecting The Ground Cables



DANGER

- Before connecting cables, ensure that the DC switches on the WIT Inverter are OFF. Turn off the switches and breakers on the GRID side, GEN side and the battery side. Otherwise, the high voltages of the WIT Inverter may result in electric shocks.
- Only qualified and trained electrical technicians are allowed to perform operations. Technicians must observe instructions in this manual and local regulations.
- High voltages may cause electric shocks and serious injury. Please do not touch the inverter in operation.
- Do not place inflammable and explosive materials around the WIT Inverter.

The Internal Ground Cables connection steps:

1) Open the lower cover and the cover position is shown in Fig 6.9;

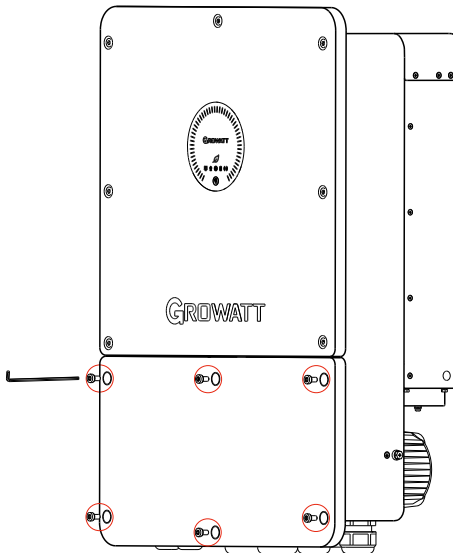

Fig 6.9 Right cover

2) Connect a ground cable to the copper grounding bar. Fig 6.10 shows the position of the grounding bar inside the right cover plate;

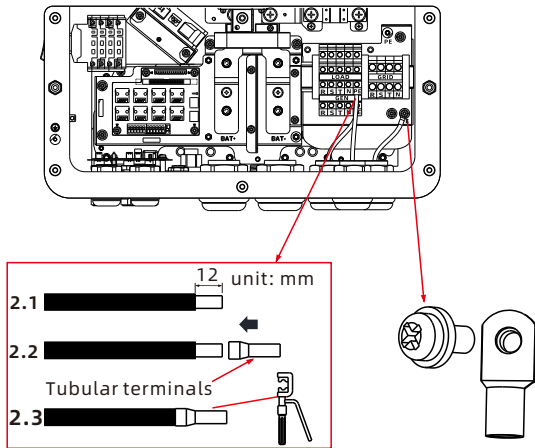



Fig 6.10 Grounding Schematic

6.3 Connection on the AC Side

 <p>DANGER</p>	<ul style="list-style-type: none"> • Before connecting cables, ensure that the DC switches on the WIT Inverter are OFF. Turn off the switches and breakers on the GRID side, GEN side and the battery side. Otherwise, the high voltages of the WIT Inverter may result in electric shocks. • Only qualified and trained electrical technicians are allowed to perform operations. Technicians must observe instructions in this manual and local regulations. • High voltages may cause electric shocks and serious injury. Please do not touch the inverter in operation. • Do not place inflammable and explosive materials around the WIT Inverter.
 <p>WARNING</p>	<ul style="list-style-type: none"> • Each WIT Inverter must be equipped with a separate AC circuit breaker. Multiple WIT Inverters cannot connect to the same AC circuit breaker (not applicable to off-grid mode). • Please do not connect loads between the WIT Inverter and the circuit breaker. • If the cable is thick, do not wiggle the cable after tightening the cable terminals. Otherwise, the loose connection may cause overheating that will damage the device. Ensure that the terminals are properly connected before starting the WIT Inverter. • Upon completion of the AC wiring, remember to seal the waterproof silicone mat with the fireproof mud in order to ensure good waterproof performance.

Preparation:

- 1> Ensure the grid voltage and the grid frequency are within the acceptable range;
- 2> Disconnect the DC switches and the AC breakers on the grid side, generator side and the battery side.

The circuit breaker on the AC side:

AC circuit breaker needs to be installed on the grid side, ensuring a safe disconnection between the WIT Inverter and the upstream input when an exception occurs.

1. Recommended AC breaker specifications for WIT 4-15K-HU models

Device type	Rated voltage of the circuit breaker	Rated current of the circuit breaker
WIT 4/5/6K-HU	400V	32A
WIT 8/10/12/15K-HU	400V	63A

2. Recommended load breaker specifications for WIT 4-15K-HU models

Device type	Rated voltage of the circuit breaker	Rated current of the circuit breaker
WIT 4/5/6K-HU	400V	25A
WIT 8/10/12/15K-HU	400V	50A

3. Recommended bypass breaker specifications for WIT 4-15K-HU models

Device type	Rated voltage of the circuit breaker	Rated current of the circuit breaker
WIT 4/5/6K-HU	400V	25A
WIT 8/10/12/15K-HU	400V	50A

4. Recommended Gen breaker specifications for WIT 4-15K-HU models

Device type	Rated voltage of the circuit breaker	Rated current of the circuit breaker
WIT 4/5/6K-HU	400V	32A
WIT 8/10/12/15K-HU	400V	63A

NOTE:

For the PCS to operate in Smart Load mode, select the appropriate AC breaker based on the smart load power.

Recommended power cable specifications:

Recommended AC power cables for WIT 4-15K-HU models

Device type	GRID Recommended cable specification	LOAD Recommended cable specification	GEN Recommended cable specification
WIT 4-15K-HU	10mm ²	10mm ²	10mm ²

Note: The wire should be well tinned and free from splits and breaks.

AC side connection method:

Connect the main power cables according to the label. Fig 6.11 shows the position of the label and the AC terminals.

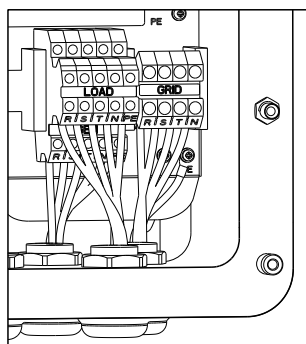
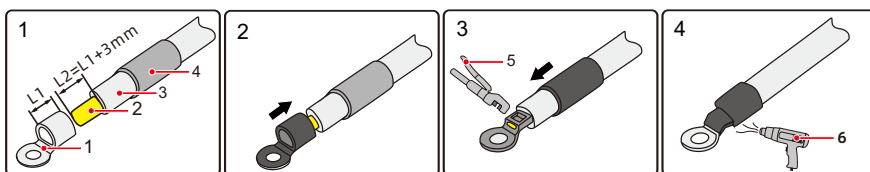

Fig 6.11 AC Terminal Wiring Locations and Schematics

Note:

1. Determine the stripped length based on the wiring terminal specifications (recommended length: 11-13 mm). Crimp the cable and terminal using a crimper as shown below. Loosen the PG type cable gland and route the cables through it. Then connect the cables to the corresponding terminals. Secure the cables by tightening the screws.





- (1) OT terminal
- (2) Core wire
- (3) Cable
- (4) Heat shrink tubing
- (5) Hydraulic pilers
- (6) Heat gun

Fig 6.12 Schematic diagram of cable crimp terminals

2. Cold-pressed terminals are delivered with the package. Select terminals based on the cable specifications;

 <p>WARNING</p>	<ul style="list-style-type: none">• Any device damage caused by failure to seal the output terminal gaps as instructed is beyond the scope of warranty and Growatt shall not be liable for the damage.
---	--

6.4 Connection on the PV Side

 <p>DANGER</p>	<ul style="list-style-type: none"> • Before connecting cables, ensure that the DC switches of the WIT Inverter are OFF, and turn off the breakers on the AC side and the battery side. Otherwise, the high voltages of the WIT Inverter may cause electric shocks. • Only qualified and trained electrical technicians are allowed to perform operations. Technicians must observe instructions in this manual and local regulations. • Check the positive and negative terminals before connecting the PV module to the WIT Inverter. • High voltages may cause electric shocks and serious injury. Please do not touch the inverter in operation. • Please do not place inflammable and explosive materials around the WIT Inverter.
 <p>WARNING</p>	<ul style="list-style-type: none"> • The maximum open-circuit voltage of each string should not exceed 1000Vdc. • Ensure that the following conditions are met; Otherwise, fire hazard or inverter damage may occur. Growatt is not liable for the consequence and it is beyond the warranty scope.

NOTE:

1. When exposed to sunlight, PV modules will generate voltage. High voltages presented in the PV strings connected in series could be fatal. Therefore, shield the PV modules from sunlight before connecting the DO input power cable and ensure that the DC switches on the WIT Inverter are OFF.
2. The PV modules connected in series should be of the same model.
The maximum short-circuit current of each PV string must be lower than or equal to 50A.
3. The total panel power should not exceed twice the WIT inverter input power.
For optimal system configuration, it is recommended to connect two DC inputs with an equal number of PV modules.

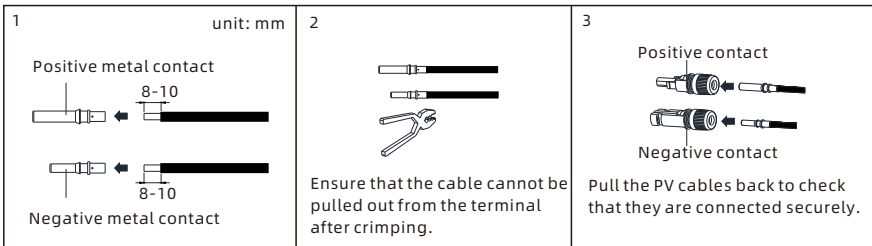

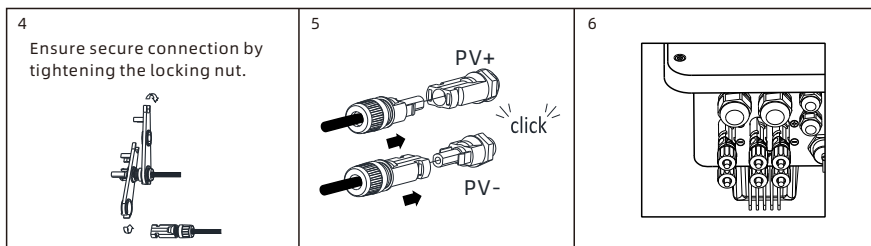

Fig 6.13 PV Terminal

Procedure for connecting cables on the PV side:

1. Strip 6-8 mm of the insulation layer of the PV cables;
2. Insert the exposed core wires into the crimping area of the wiring terminal and crimp them using a crimping plier;
3. Route the cable through the cable sealing sleeve and insert the insulation sleeve until it snaps. Slightly pull the cable back to ensure that it is securely connected. Then tighten the locking nut;
4. Insert the positive and negative connectors of the PV modules to the corresponding terminals on the inverter. For the maximum input current of different models, please see Table 6.1. For the cable specifications, please see Table 6.2.

Table 6.1 Maximum current of a single MPPT route

Device type	Max. current of a single MPPT route
WIT 4-15K-HU	40A



Table 6.2 Cable specifications on the PV side

Device type	Recommendation cable specifications
WIT 4-15K-HU	4-6mm ²

NOTE:

- 1) For a single WIT Inverter, connect the ground cable of the inverter. For a system with multiple WIT Inverters connected in parallel, connect the ground cables of all inverters and the metal racks of the PV modules to the same area to ensure equipotential bonding. Before connecting the PV cables, ensure that the ground cables on the PV side are properly connected.
- 2) Use male and female connectors in pair. Ensure the correct polarity before connecting the PV string to the inverter.
- 3) The total current of all strings cannot exceed the WIT Inverter's maximum input current;
- 4) Do not touch the solar panels in operation;
- 5) The wires should be tinned and are not frayed or cracked.

6.5 Connection on the Battery Side

 <p>DANGER</p>	<ul style="list-style-type: none"> • Before connecting cables, ensure that the DC switches of the WIT Inverter are OFF, and turn off the breakers on the AC side and the battery side. Otherwise, the high voltages of the WIT Inverter may cause electric shocks. • Only qualified and trained electrical technicians are allowed to perform operations. Technicians must observe instructions in this manual and local regulations. • High voltages may cause electric shocks and serious injury. Please do not touch the inverter in operation. • Please do not place inflammable and explosive materials around the WIT Inverter.
 <p>WARNING</p>	<ul style="list-style-type: none"> • Ensure that all cables are securely connected before powering on the WIT Inverter. Loose connection may cause overheating that will damage the device.

NOTE:

Recommended battery voltage 51.2V.

Table 6.3 Cable specifications on the Battery side

Device type	Recommended Cable Specifications
WIT 4K-HU	50mm ²
WIT 5K-HU	50mm ²
WIT 6K-HU	50mm ²
WIT 8K-HU	50mm ² /120mm ²
WIT 10K-HU	50mm ² /120mm ²
WIT 12K-HU	50mm ² /120mm ²
WIT 15K-HU	50mm ² /120mm ²

6.5.1 Connecting the Main Power Cable of the Battery

Preparation:

1. Turn off the DC switch, AC side switch and battery side switch of The WIT;
2. Find the battery OT terminal from the delivery accessories. See Accessories Diagram in Chapter 4 for the terminal picture.

Procedure for connecting the main battery power:

1. Strip the insulation layer of the DC cable, Select an appropriate cable stripping length based on the OT terminal.
2. Use crimping pliers to crimp the battery cable on the battery terminal, and then cover the heat shrink tube for insulation protection;
3. Connect the crimping terminal of the battery cable to the battery input terminal and lock it using M8 screws, as shown in Fig 6.14.

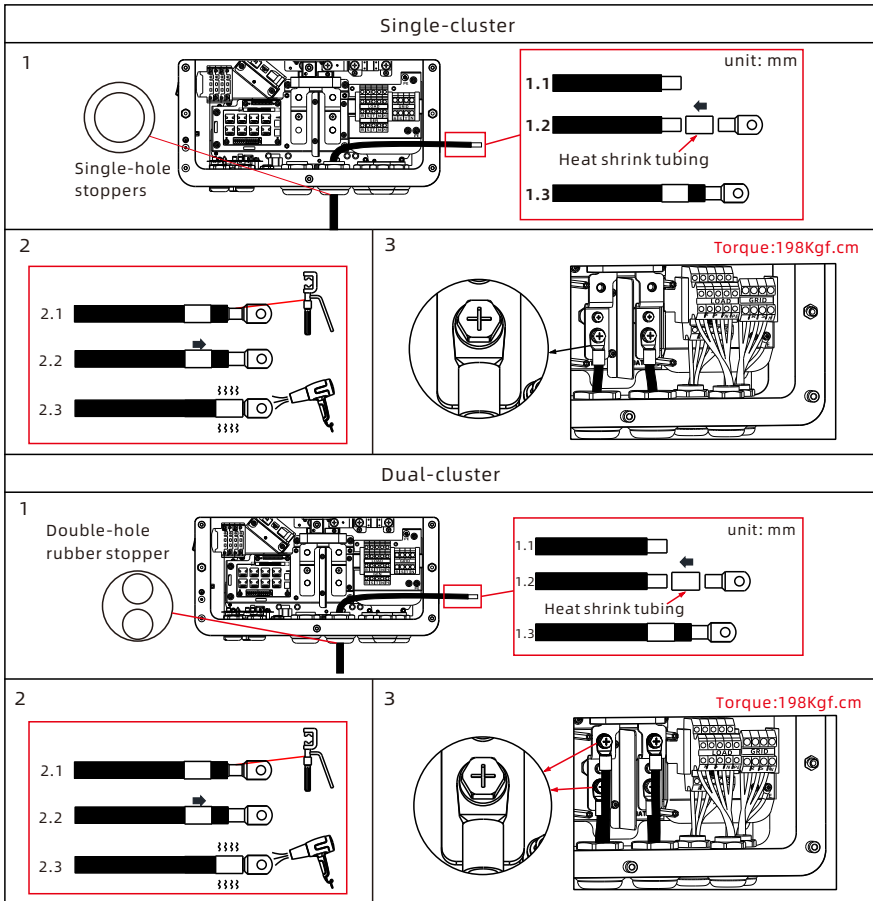

Fig 6.14 Step-by-step diagram of battery terminal wiring

NOTE:

- 1> Connect the ground cable before connecting the battery cable; the ground point is shown in Fig 6.10.
- 2> The length of the battery cable is recommended to be no more than 10m

6.6 Connecting Communications Cables

6.6.1 COM1/COM2 Connection

WIT 4-15K-HU Inverter includes 8 RJ45 ports. It is used for parallel connection via PARA-IN and PARA-OUT communication terminals, battery communication via BMS1 terminals, and external equipment communication via RS485 and DRMS function. Connect the communication cables to the corresponding terminals as required. For details, see Table 6.5.

Procedure for connecting the terminal:

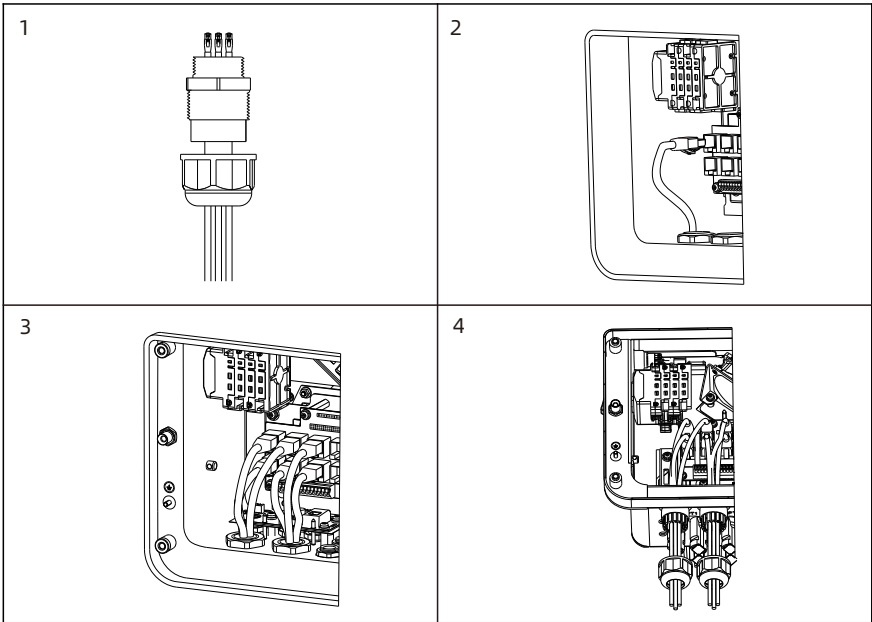

Fig 6.15

1> Unscrew the PG head to remove the rubber plugs according to the number of communication cables, keep the rubber plugs with unused holes, and then pass the communication cables through the PG head. The steps are shown in Step 1-4;

2> Crimp the communication cables as shown below.

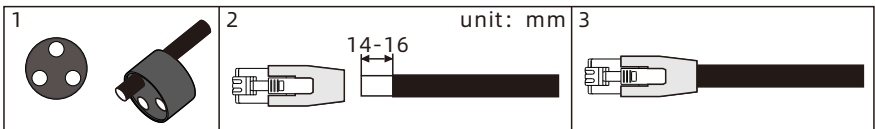

Fig 6.16

- 3> Connect the communication cable terminals according to the single board silkscreen as shown in Fig 6.17.
- 4> Tighten the PG head after connecting.

Detailed information of COM1

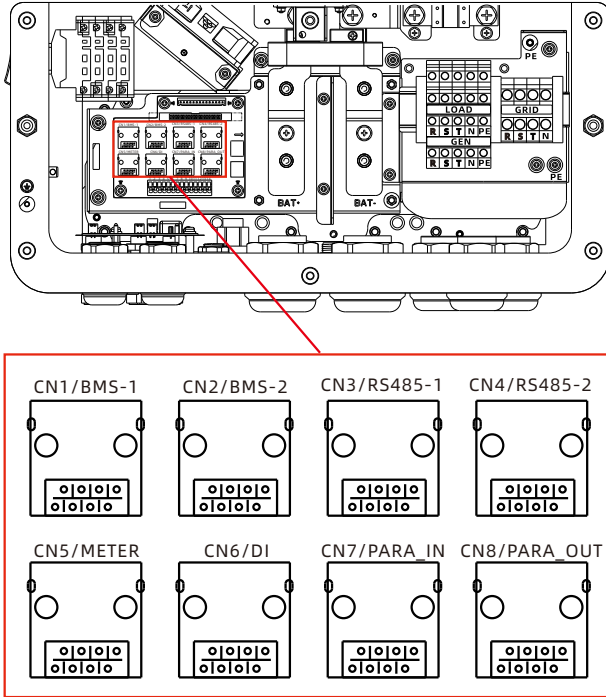

Fig 6.17 Communication network port

Table 6.5 Communication network port terminal description

Definition of battery communication terminal			
Silk screen	Pin	Definition of signal	Function and Note
BMS1	1	BAT RS485_B	Communication of battery1 (mandatory)
	2	BAT RS485_A	
	3	BAT1 DI_1	
	4	BAT1 CAN_H	
	5	BAT1 CAN_L	
	6	BAT1 DI_2	
	7	BAT1 WAKE-	
	8	BAT1 WAKE+	
BMS2	1	\	Disabled
	2	\	
	3	\	
	4	\	
	5	\	
	6	\	
	7	\	
	8	\	
RS485-1	1	RS485_1B	RS485-1: CT/ShineBus/ ShineMaster (1/4/5) RS485-3: EMS/VPP (7/8)
	2	GND.S	
	3	\	
	4	RS485_1B	
	5	RS485_1A	
	6	\	
	7	RS485_3B	
	8	RS485_3A	

Definition of battery communication terminal			
Silk screen	Pin	Definition of signal	Function and Note
RS485-2	1	RS485_1B	RS485-1: CT/ShineBus/ ShineMaster (1/4/5) RS485-3: EMS/VPP (7/8)
	2	GND.S	
	3	\	
	4	RS485_1B	
	5	RS485_1A	
	6	\	
	7	RS485_3B	
	8	RS485_3A	
METER	1	RS485_2B	RS485_2: METER1 output (export limitation meter wiring port for a single inverter)
	2	GND.S	
	3	\	
	4	\	
	5	RS485_2A	
	6	\	
	7	\	
	8	\	
DI	1	DRM1/5	DRMS/RCR/DI function
	2	DRM2/6	
	3	DRM3/7	
	4	DRM4/8	
	5	REF	
	6	COM	
	7	\	
	8	\	

Definition of battery communication terminal			
Silk screen	Pin	Definition of signal	Function and Note
PARA-IN	1	\	Parallel input
	2	GND.S	
	3	Sc_A/H	
	4	PL_CANH	
	5	PL_CANL	
	6	Sc_B/L	
	7	GND.S	
	8	Master_CAN	
PARA-OUT	1	\	Parallel output
	2	GND.S	
	3	Sc_A/H	
	4	PL_CANH	
	5	PL_CANL	
	6	Sc_B/L	
	7	Slave_CAN	
	8	GND.S	

6.6.2 COM3/COM4 Connection (Connecting the signal terminals)

This terminals is used for oiler start/stop, machine emergency stop, battery temperature rise and external CT access signals.

Terminal Connection Procedure.

- 1) Strip the outer wire skin of the cable by 5~7mm, and then use crimping pliers to crimp the wire and tubular terminal;
- 2) Unscrew the corresponding PG head and remove the rubber bar under the corresponding hole, keep the rubber plug for the unused hole;
- 3) Pass the cable through the PG header and snap it into the corresponding terminal holes of the veneer as shown in Fig 6.18.

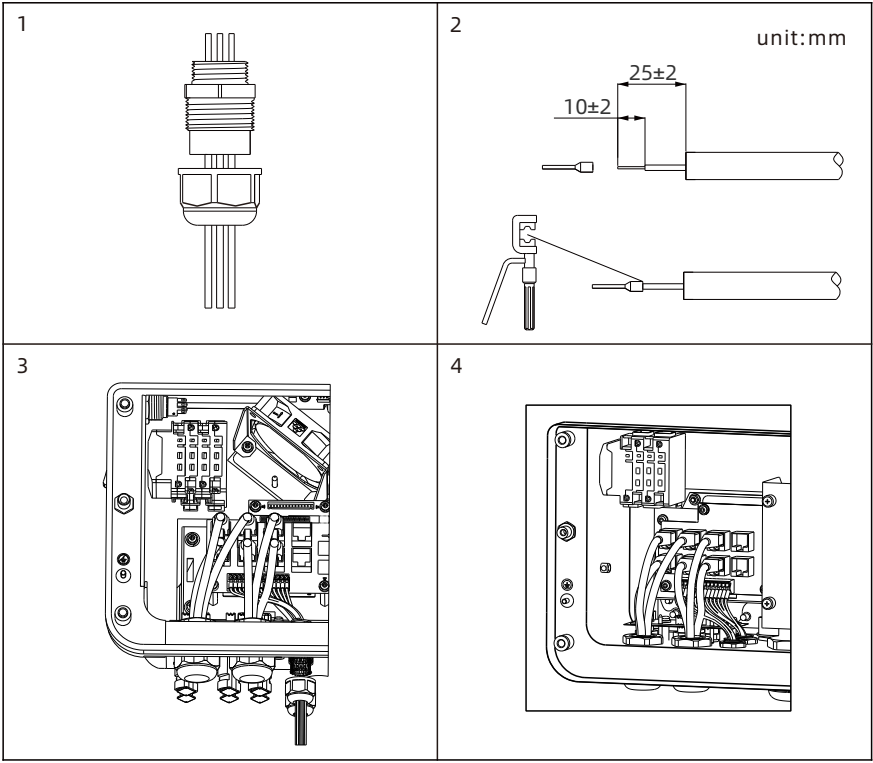

Fig 6.18 Signal terminal connections

4) Install the Bottom cover plate after completing all the above steps.

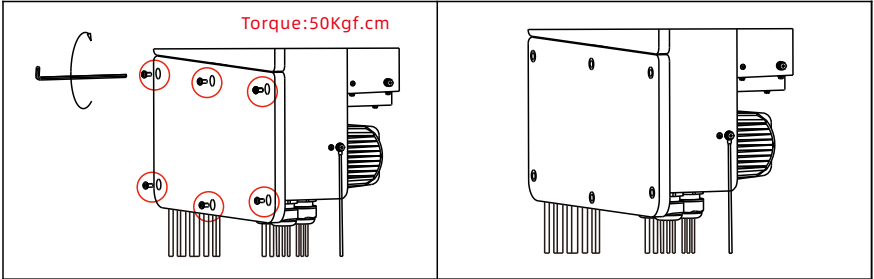

Fig 6.19 Install the Bottom cover plate

Detailed information:

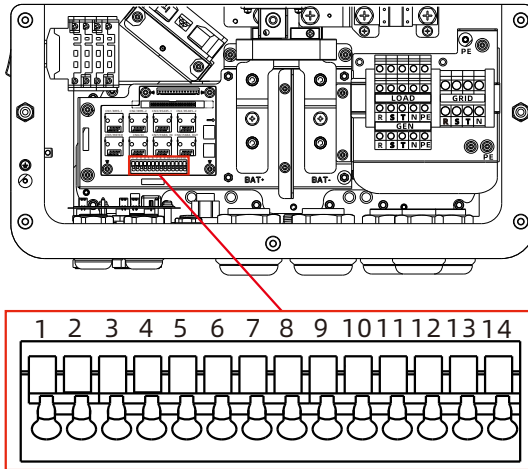

Fig 6.20 Signal Terminal

Signal Terminal Interface Definition Description			
silkscreen	Pin	Signal Definition	Features and Remarks
COM3(CN10)	1	REPO.WIT	Emergency shutdown input
	2	GND.S	
	3	DG_START+	Oiler start signal
	4	DG_START-	
	5	NTC.BAT1 OUT	Battery 1 temperature
	6	NTC.BAT1 OUT.G	
COM4(CN10)	7	\	\
	8	\	
	9	CT_R+ (White)	CT Phase A
	10	CT_R- (Black)	
	11	CT_S+ (White)	CT Phase B
	12	CT_S- (Black)	
	13	CT_T+ (White)	CT Phase C
	14	CT_T- (Black)	

6.6.3 USB connection

The WIT-XHU series inverter is equipped with a USB interface as standard, which can be connected to a USB to WiLAN-X2 monitoring module for remote monitoring. In addition, you can also quickly upgrade the inverter software through the U disk. Steps to install the monitoring module:

- 1> Loosen the waterproof cover of the USB interface and remove it.
- 2> As shown in Fig 6.21, insert the WiLAN-X2 module into the USB interface, and the LED indicator of the WiLAN-X2 module will be on.
- 3> As shown in Fig 6.21, make sure that the is facing frontwards as the inverter has been wall-mounted, insert the monitoring module into the USB interface, and tighten the lock.

Note:

If a USB to WiLAN-X2 module is installed, please take the module and the data cable away, and tighten the waterproof cover when the operator leaves to prevent water from entering the interface.

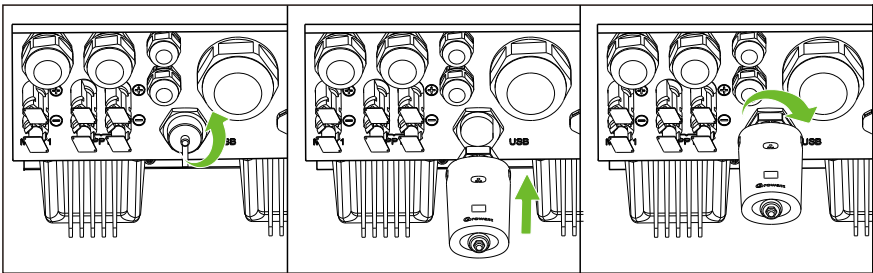

Fig.6.21 USB Connection

6.7 Post-installation Checks

The following table lists the post-installation items to be checked:

Position	Item	Check item
housings	Ground cable connected to the chassis	Check the cable specifications; ensure that the cable has been securely fastened
PV side	Ground cable on the PV side	Check the cable specifications; ensure that the cable has been securely fastened
	PV+, PV-	Check the cable specifications; ensure that the cable has been securely fastened; confirm that the number of PV modules matches the rated power



Position	Item	Check item
Battery side	Ground cable on the battery side	Check the cable specifications; ensure that the cable has been securely fastened
	BAT+, BAT-	Check the cable specifications; ensure that the cable has been securely fastened
AC Side	Ground cable on the AC side	Check the cable specifications; ensure that the cable has been securely fastened
	Grid side	Check the cable specifications; ensure that the cable has been securely fastened
	Load side	Check the cable specifications; ensure that the cable has been securely fastened
	GEN side	Check the cable specifications; ensure that the cable has been securely fastened
	Right cover plate	Re-install the cover and secure it with screws after checking all items on the AC side
Communication terminals	Network Port Terminal	Connections are correctly made without loosening and are locked
	signal terminal	Connections are correctly made without loosening and are locked
	USB	No loosening of the correct insertion, no gaps in the sealing ring
bottom cover	bottom cover	Please make sure that the wiring is correct and then cover the lower cover of the machine and lock it tightly

Note:

After the wiring is completed, please make sure to check that the lower cover plate is installed reliably to ensure that the protection level of the machine is not affected by installation problems.

Commissioning 7

7.1 Commissioning the WIT Inverter

	<ul style="list-style-type: none">• The WIT Inverter might show wrong time and date if it has been stored for over a month. You need to set the correct time and date before connecting the WIT Inverter to the grid.
 WARNING	<ul style="list-style-type: none">• When The WIT is only connected to the battery, the battery switch must be pressed until the battery is fully awakened.

7.1.1 Set the Communication Address

After the WIT Inverter is powered on, you can set the communication address of the WIT Inverter via RS485 communication or the USB to WiLAN-X2 module. When multiple inverters are connected in parallel with RS485 hand-in-hand communication, each inverter should be set to different communication addresses. For a single inverter, the default communication address is set to 1.

NOTE:

The communication address of the WIT Inverter ranges from 1 to 254. By connecting the WIT Inverter to the host computer through RS485 communication, you can change its communication address via Shinebus. This operation should be performed by professional personnel.

7.1.2 Set the Time and Date

7.1.2.1 Set the time and date on the APP (Shinephone/Shinertools)

Follow the instructions in Section 6.5.3 to connect the datalogger. Take Shinephone APP as an example, When the inverter is powered in, you can set inverter time and date referring to Section 8.1.1. Tap Control > Set Inverter Time, then enter the password "growatt+date". For instance, if the date is Feb. 28, 2024, the password would be "growatt20240228". After that, tap "Yes".

1. Set the correct date, then tap "OK". Proceed to set the time, and tap "OK".

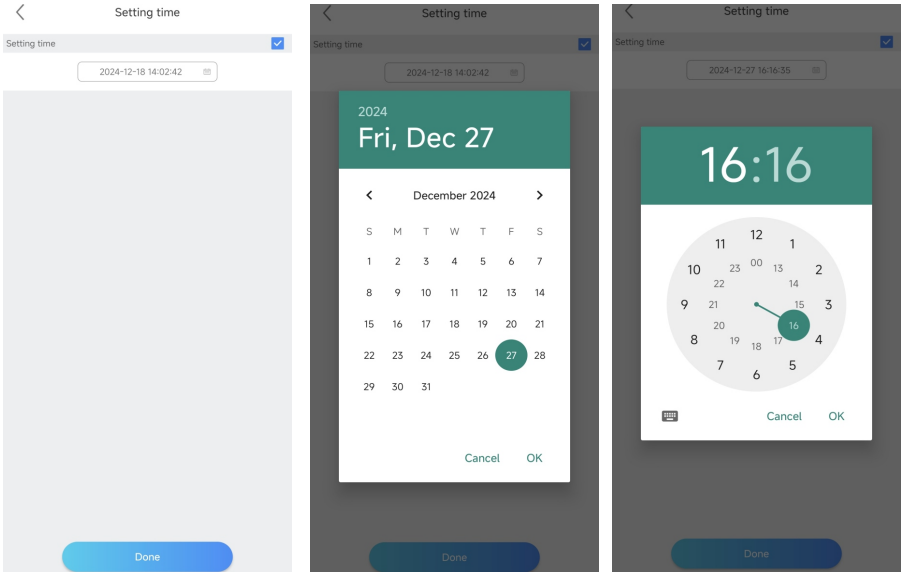

7.1.2.2 Set the Date & Time Automatically

Connect the WIT Inverter to the server following the procedure specified in Section 8.1.2 when the inverter is powered on, then the WIT Inverter will update its date and time automatically.

7.2 Mode of operation

7.2.1 Waiting Mode

When the PV voltage is greater than 150V, the WIT Inverter will be powered on and enters the waiting mode.

In waiting mode, the WIT Inverter performs self-check. If the system is normal and the voltage is greater than or equals to 165V, the WIT Inverter will be powered on.

7.2.2 Operating Mode

7.2.2.1 Operating Mode of WIT 4-15K-HU

Load First:

In Load First mode, the WIT inverter prioritizes supplying the solar power and battery energy to the loads. If Export Limitation is disabled, the surplus solar power can be fed to the grid, but the battery energy will not be exported to the grid; if Export Limitation is enabled, neither solar power nor battery energy would be sent to the grid.

Priority of power supplied to the loads:

1. Solar panels;
2. Batteries;
3. Grid.

NOTE: In Load First mode, a meter is required.

Battery First:

In Battery First mode, the solar power is prioritized towards charging the battery until the battery SOC (state of charge) reaches the preset upper threshold. Then it will supply power to the loads. The further excess solar power, if any, can be fed to the grid (Export Limitation disabled). In case that the solar power is insufficient, the WIT inverter will draw power from the grid to charge the battery or supply the loads.

Priority of power directed to charge the battery:

1. Solar panels;
2. Grid.

Grid First:

In Grid First mode, the WIT inverter prioritizes supplying the solar power to the loads, exports the excess solar power to the grid, and sends the further surplus power to charge the power. If the solar power is insufficient to support the loads, the battery will discharge to supply power to the loads and the surplus battery power will be sent to the grid for revenue.

Priority of power supplied to the loads:

1. Solar panels;
2. Batteries;
3. Grid.

Zero export to meter:

With Export Limitation enabled, no solar power or battery energy will be fed to the grid in this mode. The inverter output is only supplied to the loads connected before the external meter connection point. A meter is required. For the meter wiring mode, please refer to Fig 6.6 in Chapter 6. The external meter will detect power flowing to the grid and regulate the generated power so that only so much energy is generated as is currently consumed by the primary loads, secondary loads and charging the battery.

NOTE: The arrow at the bottom of the CT should point to The WIT.

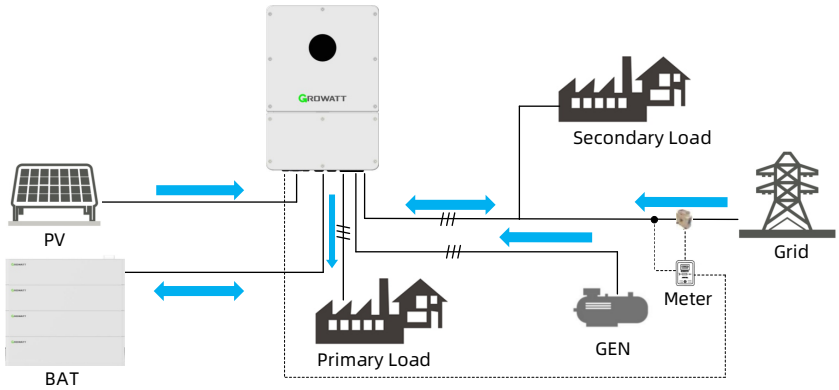

Zero export to GRID:

In this mode, there is no output at the inverter's GRID port. The solar and battery power can only be supplied to Primary Loads via the LOAD port. The meter is not required.

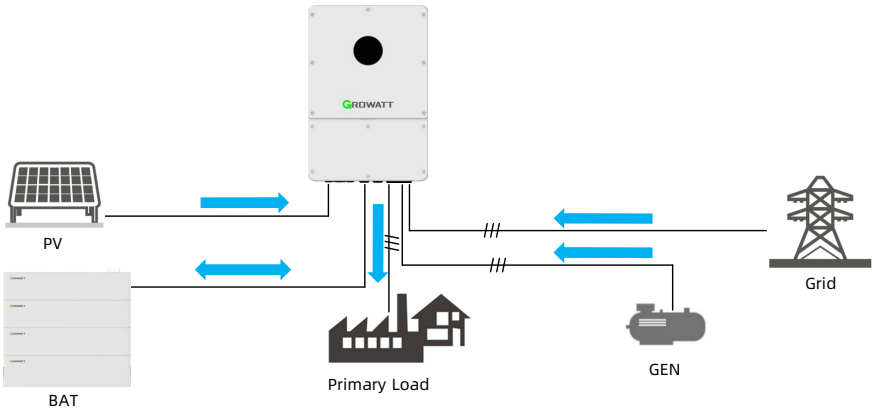

Smart Load:

Smart loads are connected to the GEN port and the Smart Load mode is set: during on-grid operation, it will supply grid power to smart loads; during off-grid operations, the power supply to smart loads is cut off when the battery SOC is below 50%. The wiring method is shown in Chapter 6 Fig 6.3.

AC couple:

The grid-tied inverter is connected to the GEN port and the AC Couple mode is set: during on-grid operation, the grid-tied inverter will be connected to the grid and generate electricity via the GEN port; during off-grid operation, the grid-tied inverter remains connected to the WIT inverter and generating power. The wiring method is shown in Chapter 6 Fig 6.2.

7.2.2.2 System Operating Strategies of WIT 4-15K-HU

TOU (Time of use):

Configure the system to work in the preset mode during different time segments based on the peak-valley periods and electricity price. Setting items include: the operating mode, enable/disable AC Charging function (charge from grid). During the time not specifically configured, it will operate according to the system settings.

The screenshot shows a 'Setting' dialog box with the following configuration:

- Advanced Setting** (expanded):
 - Maximum spontaneous self use: Disable
- Equipment mode selection and time setting** (expanded):
 - Time Slot 1:
 - Mode: Load First
 - Time Range: 17 : 43 ~ 17 : 46
 - Percentage: 10 %
 - Enable/Disable: Enable
 - Time Slot 2:
 - Mode: Load First
 - Time Range: 17 : 20 ~ 17 : 21
 - Percentage: 80 %
 - Enable/Disable: Disable
 - Time Slot 3:
 - Mode: Load First
 - Time Range: 17 : 28 ~ 17 : 31
 - Percentage: -55 %
 - Enable/Disable: Disable
 - Time Slot 4:
 - Mode: Load First
 - Time Range: 17 : 32 ~ 17 : 33
 - Percentage: 0 %
 - Enable/Disable: Enable

At the bottom, there is a 'Please Enter Password' field and three buttons: 'Yes' (highlighted in blue), 'Advanced Setting', and 'Cancel'.

Self-consumption:

The WIT inverter prioritizes supplying the solar power and battery energy to the loads. If Export Limitation is disabled, the surplus solar power can be fed to the grid, but the battery energy will not be exported to the grid; if Export Limitation is enabled, neither solar power nor battery energy would be sent to the grid. In case that the solar power is insufficient, the battery will discharge to power the loads. Priority of power supplied to the loads:

1. Solar panels;
2. Batteries;
3. Grids.

NOTE: In Load First mode, a meter is required.

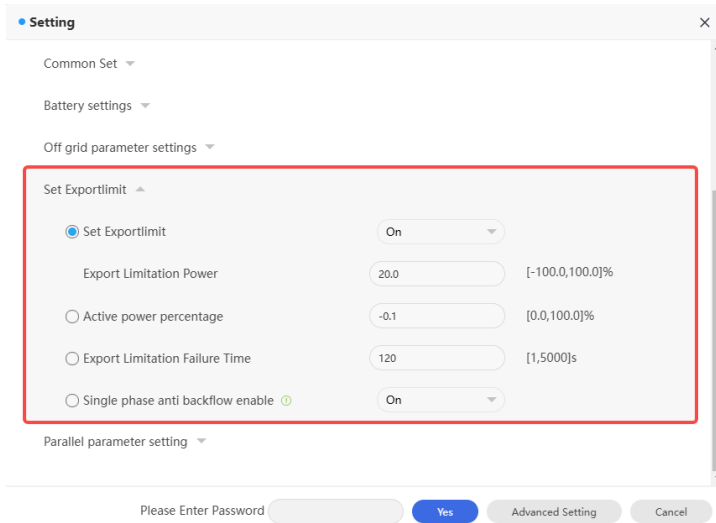

Grid Peak Shaving:

Set the forward power flow threshold A: once the load power on the external meter is greater than this value, the inverter will reduce charging power and boost power out until it reaches the maximum operating power of the WIT inverter. Set the reverse power flow threshold B: once the grid feed-in power on the external meter is greater than this value, the inverter will reduce output power and boost charging power until it reaches the maximum operating power of the WIT inverter.

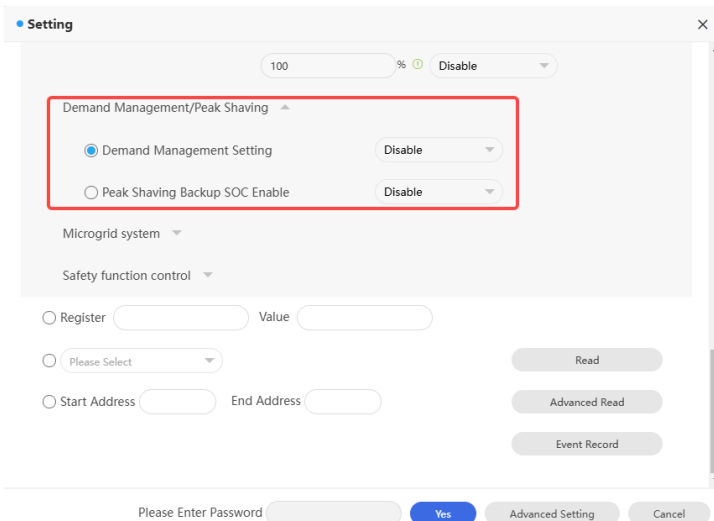

Micro-grid (PV-ESS-DG Power System):

A generator is connected to the GEN port:

If the grid power is normal, the WIT inverter will work in the grid-tied mode:

1. If the power generated by the grid-tied inverter is sufficient to support the loads, the surplus power will be used to charge the battery;
2. If the power generated by the grid-tied inverter is sufficient, the WIT inverter will supply the solar power to the loads, and direct the surplus power to charge the battery;
3. If the solar power of the WIT inverter is insufficient, the battery will discharge to power the loads;
4. The battery will stop discharging when the SOC is lower than the cutoff threshold and it will draw the grid power to support the loads;

If the grid power is abnormal, the WIT inverter will work in the off-grid mode:

1. The solar power of the WIT inverter is supplied to the loads first, and the surplus power is sent to charge the battery.
2. If the solar power of the WIT inverter is insufficient, the battery will discharge to power the loads.
3. When the battery SOC is lower than the preset diesel generator startup threshold, the GEN will start automatically to generate power
4. If charging from the GEN is enabled, the GEN will charge the battery.
5. When the battery SOC is higher than the preset diesel generator shutdown threshold, it will disconnect the GEN, and shut down the GEN

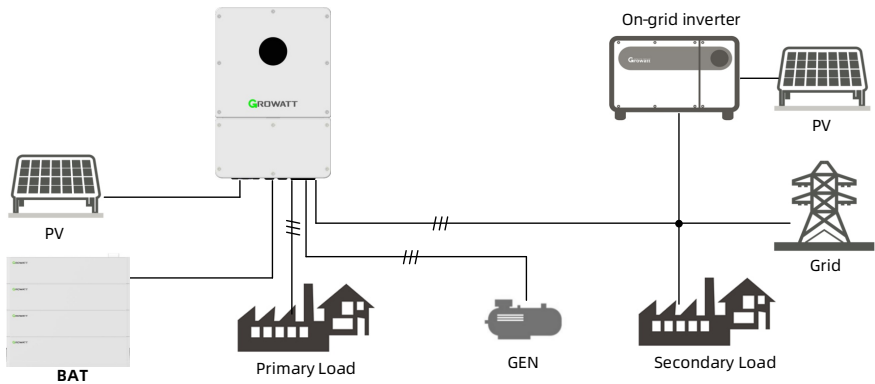

User-defined dry contact:

After enabling the user-defined DI port and inputting the DI signal, it will carry out the AC active power and power factor according to the corresponding DI instructions.

Note:

1. The User-defined dry contact and DRMS share the same port.
2. Only one DI signal can be input at the same time.

7.2.3 Fault Mode

The intelligent control system of the WIT Inverter monitors and adjusts the system status in real time. When the WIT Inverter detects an alarm, the corresponding status light will turn red and the OLED will display the alarm. When the WIT Inverter detects a fault, the system status indicator and the corresponding status light will turn red and the OLED will display the fault. After the fault or alarm is cleared, the system recovers and all status indicators will be steady green.

NOTE: For details about faults and alarms, please see 9.2 Troubleshooting.

7.2.4 Shutdown Mode

When the battery SOC is lower than the discharge cutoff SOC and the PV string output power does not meet the requirements for grid-tied power generation, the WIT Inverter will automatically shut down. In shutdown mode, the inverter still consumes a bit energy (PV>Grid>Battery) to wait to start up again when the operating requirements are met.

NOTE:

When the PV input voltage is less than 150V or the battery input voltage is less than 40V, the WIT inverter will automatically shut down.

7.3 LED and OLED Displays Panel

The LED and OLED display panel demonstrating the running status of the WIT Inverter is shown in the Fig 7.6. The symbol description is shown in Table 7.1; The user interfaces are shown in Fig 7.7, and the LED indicator description is shown in Table 7.2.

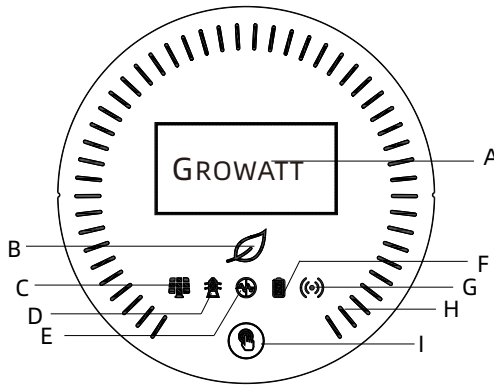

Fig 7.1 Display panel

Table 7.1 Symbol Description

Position	Description	Note
A	OLED screen	Displays the main system information
B	System indicator	Displays the system status
C	PV indicator	Indicates the operation status on the PV side
D	Grid/GEN indicator	indicates the operation status on the grid side and the GEN port status
E	Off-grid indicator	Indicates whether the off-grid mode is enabled
F	Battery indicator	Indicates the status of the battery
G	Communication	Indicates the communication status and other system faults
H	Battery status indicator	Indicates the charging and discharging mode of the battery
I	Button	You can switch the information displayed on the OLED by pressing the button

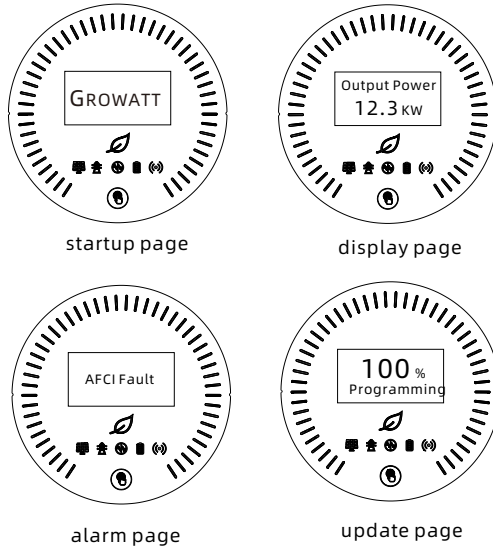











Fig 7.2 User interfaces

Table 7.2 Indicator description

	Status	Meaning
	Off	The system is not operating
	Steady green	The system is operating properly
	Blinking green at long intervals	The system is in standby mode or performing an upgrade
	Steady red	System failure
	Off	The PV voltage dose not reach the operating voltage
	Steady green	The PV voltage reaches the operating voltage
	Steady red	A fault or alarm is reported on the PV side
	Off	The grid voltage does not reach the operating voltage or the GEN is nomal
	Steady green	Successfully connected to the grid
	Blinking red at long intervals	A fault or alarm is reported on the GEN side
	Steady red	A fault or alarm is reported on the grid side

	Status	Meaning
	Off	Off-grid mode is disabled
	Steady green	Off-grid mode is enabled and has no faults or alarms
	Steady red	Off-grid mode is enabled and a fault or alarm is reported on the AC side
	Off	Battery voltage is below the operating voltage
	Steady green	The SOC's connected to the battery are all sufficient and there are no faults or alarms
	Blinking green at long intervals	Low battery SOC
	Steady red	A fault or alarm is reported on the battery side
	Steady green	External communication is normal, such as RS485, WiLAN, etc.
	Blinking green at long intervals	The WIT Inverter is upgrading or the USB interface is reading and writing data
	Steady red	External communication fails, or a system fault occurs, or the GEN port fails
	Steady white	Battery is in standby mode
	Rotates clockwise	Charging mode
	Rotates anticlockwise	Discharging mode
	Displays critical system information. Users can call up and switch the interface by tapping the button. When a fault or alarm occurs in the system, the fault or alarm will be displayed.	
	The OLED will be activated when the button is pressed. The OLED will turn off if there is no operation for 5 minutes.	

8 Monitoring

8.1 Remote Monitoring

Growatt WIT 4-15K-HU Hybrid inverters support Bluetooth/remote monitoring, which can be enabled by installing a datalogger. For more information on operation and configuration methods, see the following link.

Compatible Datalogger	Installation & Operation Guide Linkage
ShineWiLAN-X2	https://oss-eu.growatt.com/common/knowledgeShareH5No?lang=en&type=159

Scan the following QR code or search for “ShinePhone” and “Shinetools” in Google/Apple Store to download and install the mobile APP.



NOTE:

- (1) Download and install the latest version of ShinePhone.
- (2) See <https://server-us.growatt.com/?lang=en> for details.
- (3) Shinephone and Server accounts are universal.

8.1.1 Bluetooth Monitoring on the APP (Shinetools)

1. Open the ShineTools APP. On the login screen, tap "End User" and enter the password, which is in the format of "oss + the current date". E.g. oss20241225. Then tap "Sign in".
You can tap "Automatic log-in" to select whether to Log in automatically. as the figure shows.

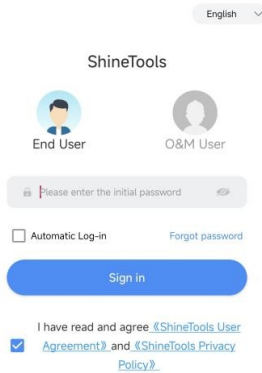

正式环境

2. Tap "ShineWiLan-X2", View connection guide, as the fig shows.

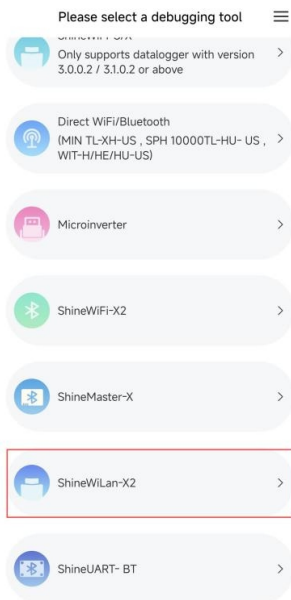



Step 3/3
ShineTools will automatically search and connect the collector Bluetooth. If ShineTools searches for multiple Bluetooth, please select the Bluetooth that is consistent with the SN number of the collector to connect.



External collector connection tutorial

Step 1/2
Please make sure that the Bluetooth of the collector is turned on (the blue light is always on), if not, please short press the button to turn on the Bluetooth.

Next step



External collector connection tutorial

Step 1/2
Please make sure that the Bluetooth of the collector is turned on (the blue light is always on), if not, please short press the button to turn on the Bluetooth.



Step 2/2
Scan the code to connect to the device.



Next step

3. After confirming that the Bluetooth of the Datalogger is enabled, scan the two-dimensional code of the Datalogger for connection, as the figure shows.



4. tap "Connect" after the target Bluetooth device is displayed. After successful connection, the screen is shown in the figure.

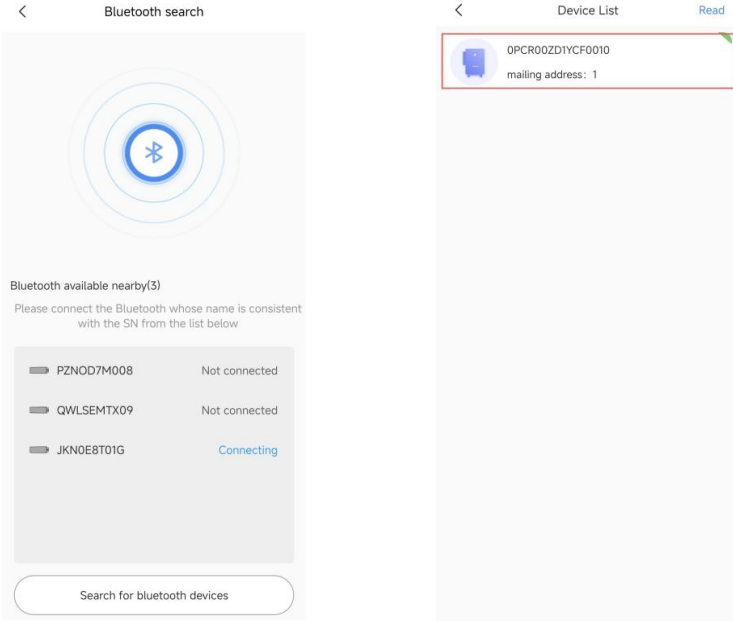

5. When the device is successfully connected, tap the Device you want to check in the Device List to view the relevant status information and set relevant parameters as required. the screen as demonstrated below will appear, ensuring that the communication between the WIT inverter and the mobile phone has been established via Bluetooth.

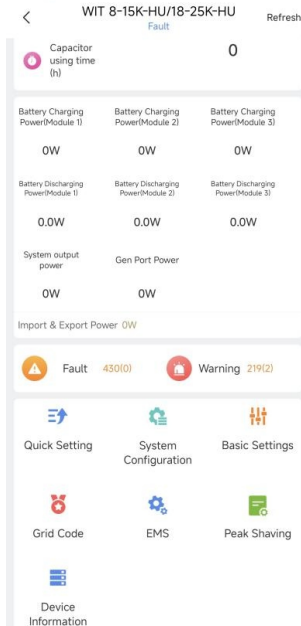
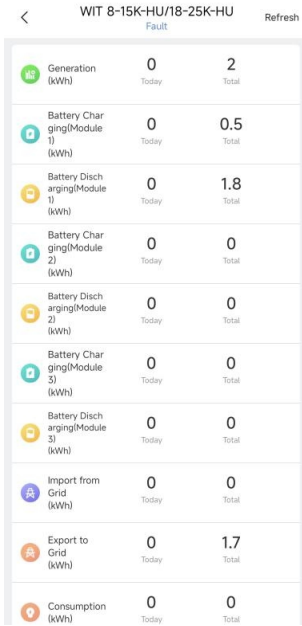

Tap Quick Setting, set time, language, etc., as the figure shows.

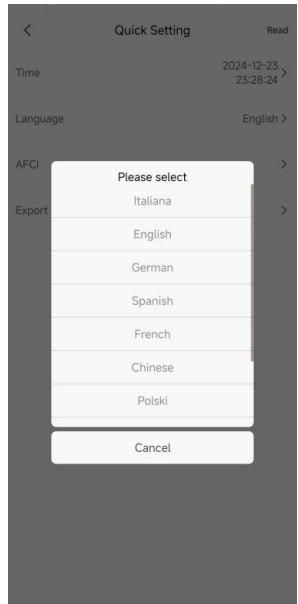
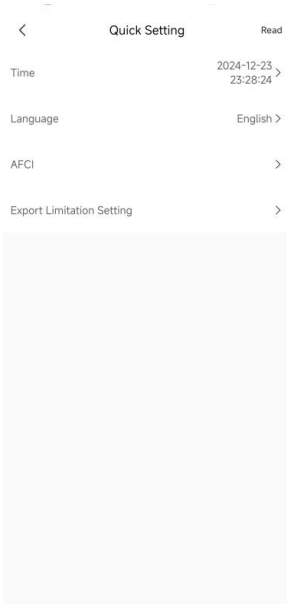

Tap System Configuration, you can turn on/off the inverter, set the percentage of active power, etc., as the figure shows.

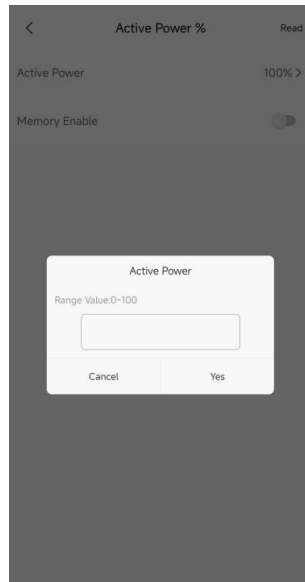

Tap on the Basic Settings, you can set the baud rate, view the network communication protocol version, as the figure shows.

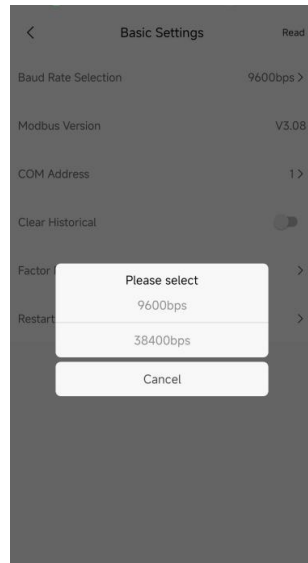
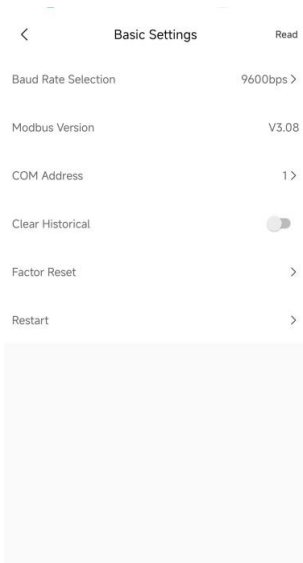

Tap Grid Code, you can set power factor related parameters, Frequency/Watt, etc., as the figure shows.

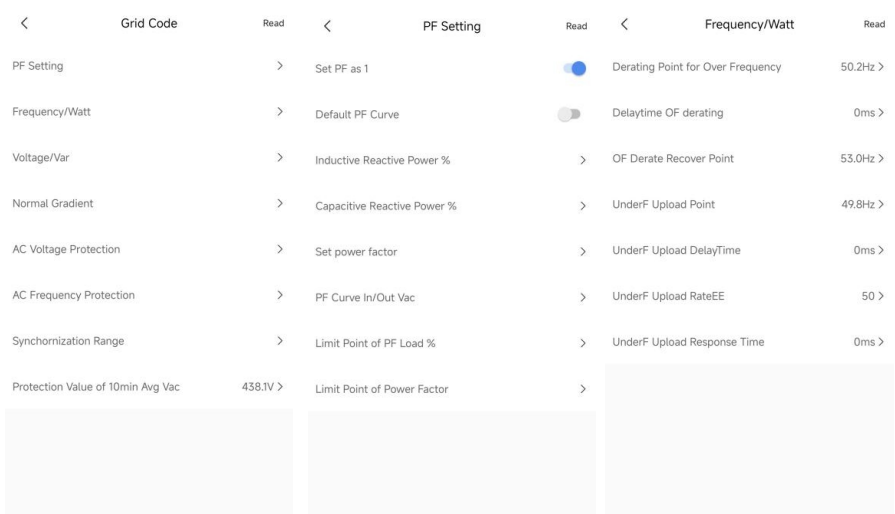

Tap EMS, you can set the use time, AC charging enable and other related information.as the figure shows.

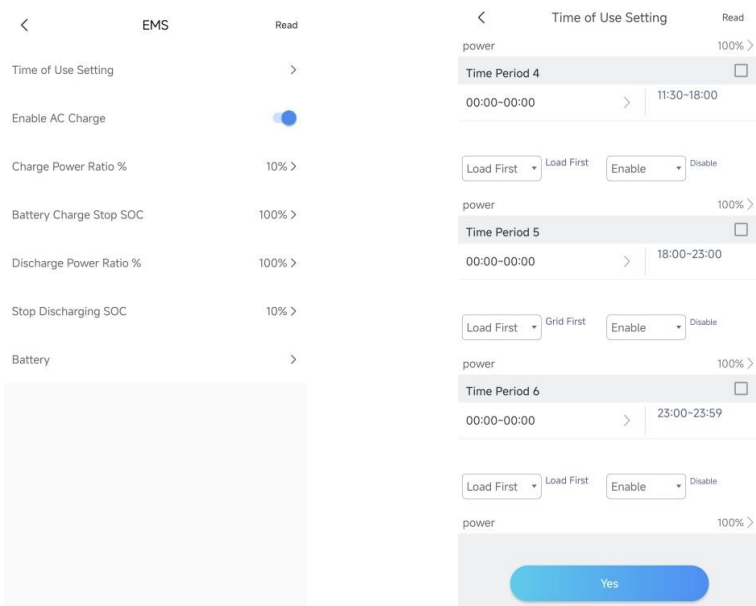

Tap Peak Shaving to Enable/disable Demand management Enable and set Demand Mange Charge Power Limit as the figure shows.

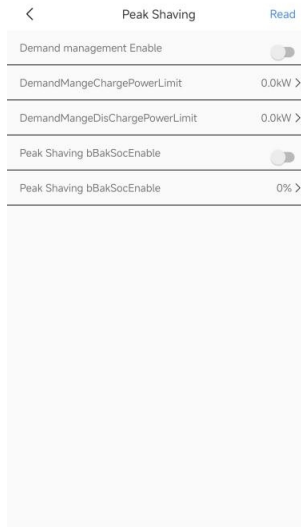

Tap Device Information, and then select the section you want to know, you can view the relevant content on the screen, as the figure shows.

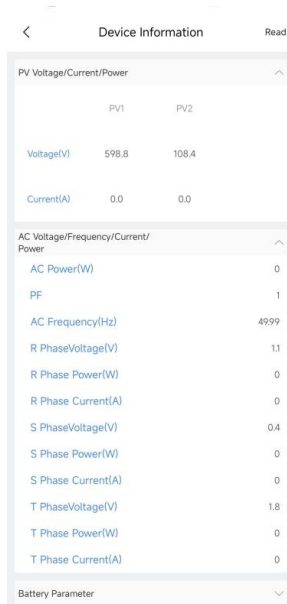
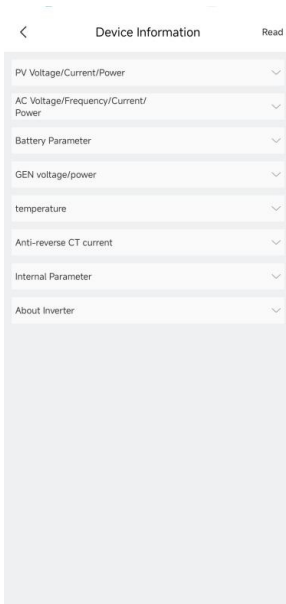

8.1.2 Remote Monitoring on the APP (ShinePhone)

NOTE:

- (1) Download and install the latest version of ShinePhone.
- (2) See <https://server.growatt.com/?lang=en> for details.
- (3) Shinephone and Server accounts are universal.

Account Registration on ShinePhone

Run the APP and tap “Register” on the login page. Fill in the information as required. Fields marked with * are mandatory. Tick the checkbox to agree to the Privacy Policy. Once the account is successfully registered, you can log in to the home screen. The registration page is shown below:

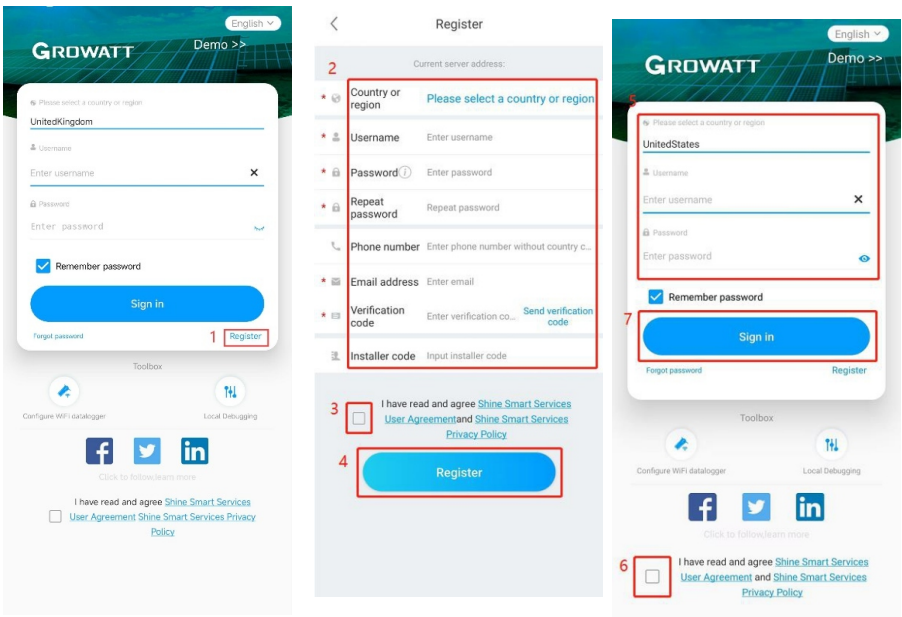

Add Plant

After logging in to ShinePhone, tap on "Plant" and follow the steps shown, Fill in the information as required. Fields marked with * are mandatory.

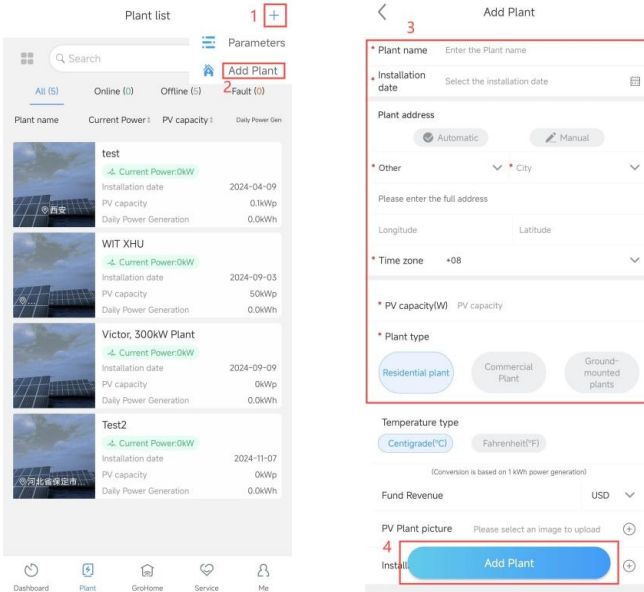

Connect the Datalogger to the network on shinephone

Perform operations according to the steps shown in the figure. Note that the Bluetooth of the Datalogger must be enabled, that is, the blue light of the Datalogger is on.

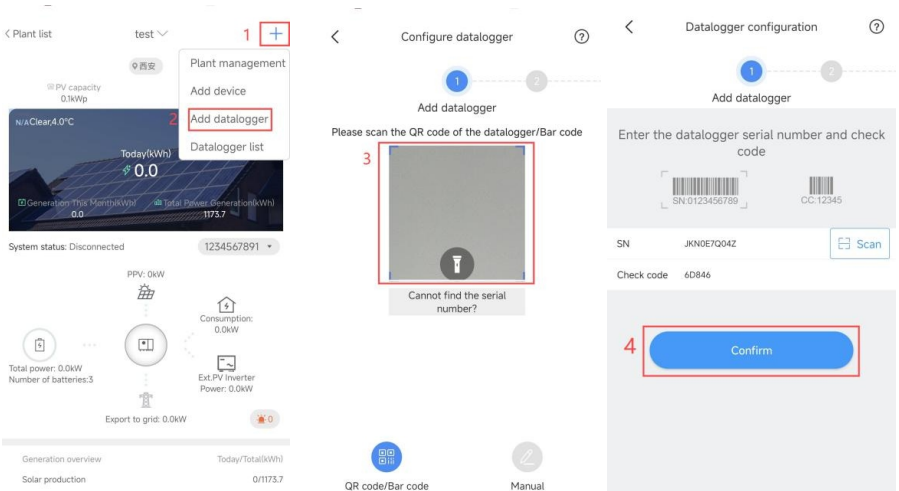

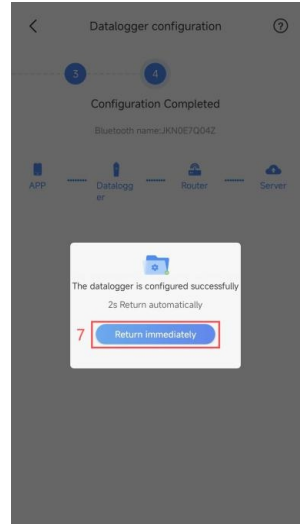

Home Screen of ShinePhone

1.Dashboard: displays the critical information of all power plants under the account, such as the total yield, the total revenue and the status of the device. Please refer to the figures below:



2. Plant: displays the plant list and the basic information about each PV plant, as shown in the figure below. You can select your target plant to view detailed information.



Detail Page of the WIT Inverter:

To access details about the WIT Inverter or related devices:

- (1) Tap "Plant" and the "Plant List" will be displayed. Select your target plant, then you can access the real-time data and history record of the power plant;
- (2) Select the WIT Inverter marked with its SN from "My device list". The figures below show QWL0DC3008 as an example;
- (3) On the Detail Page, you can view information about the inverter and related devices. Three sections - "Events", "Control" and "Edit", are available at the bottom.

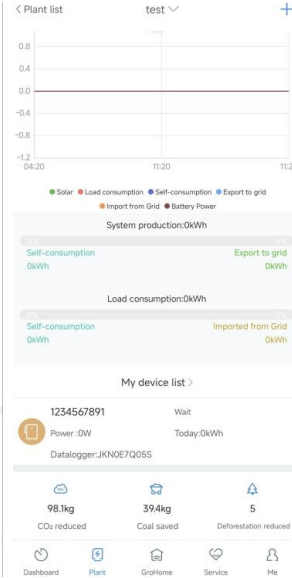
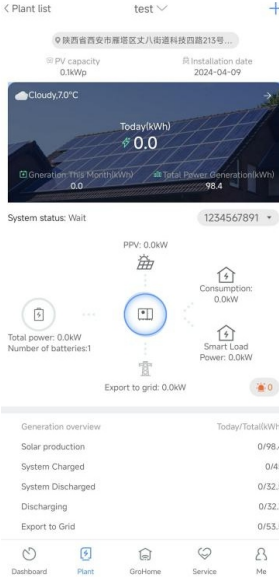

(4) On the “Events” screen, you can view the fault/warning message and suggested trouble-shooting measures.



(5) On the “Control” screen, you can configure the WIT Inverter. The password is in the format of “growatt + the current date”, e.g. growatt20240228.

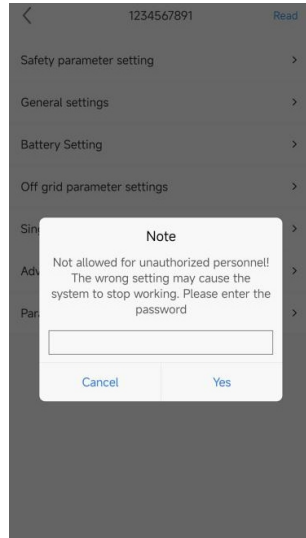
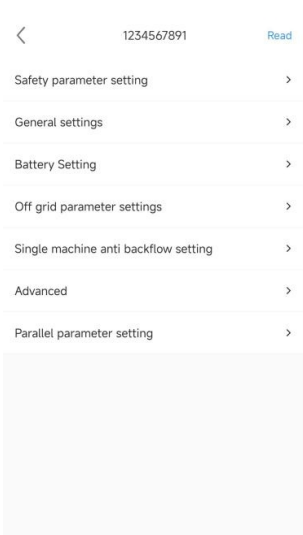

➤ **Set lower frequency limit**

Tap Control > Safety parameter setting > UV1/UV2/UV3 Frequency; You can set the lower frequency limit of The WIT.



➤ **Set frequency Upper limits**

Tap Control > Safety parameter setting > OV1 / OV2 / OV3 Frequency; You can set the upper frequency limit of The WIT.



➤ **Set lower voltage limit**

Tap Control > Safety parameter setting > UV1 / UV2 / UV3 Voltage; You can set the lower voltage limit of The WIT.



➤ **Set upper voltage limit**

Tap control >Safety parameter setting >OV1/OV2/OV3 Voltage; You can set the upper voltage limit of The WIT.

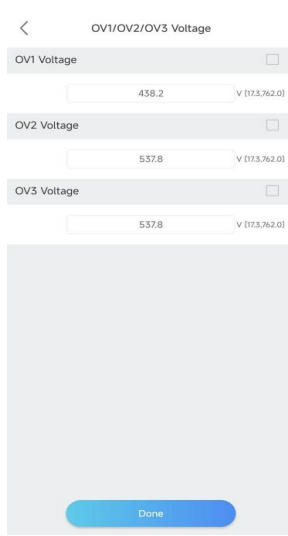

➤ **Grid related settings**

Tap Control >Safety parameter setting> Grid related settings, you can set the voltage Over/lower threshold of grid connection and the frequency Over/lower threshold of grid connection, as the figure shows.



➤ **Loading, restarting, and unloading rates**

Tap Control > Safety parameter setting > Loading, restarting, and unloading rates; you can set Loading, restarting, and unloading rates.

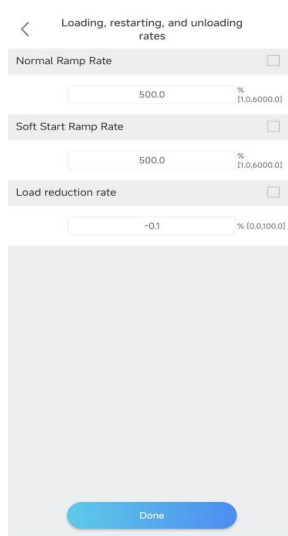

➤ **Settings related to OF derating**

Tap Control > Safety parameter setting > Loading, restarting, and unloading rates; You can set OF derating.

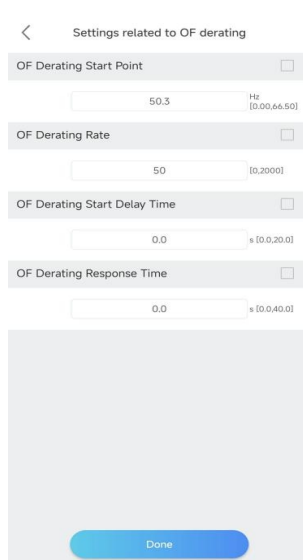

➤ **Settings related to UF increasing**

Tap Control > Safety parameter setting > Loading, restarting, and unloading rates; You can set UF derating.

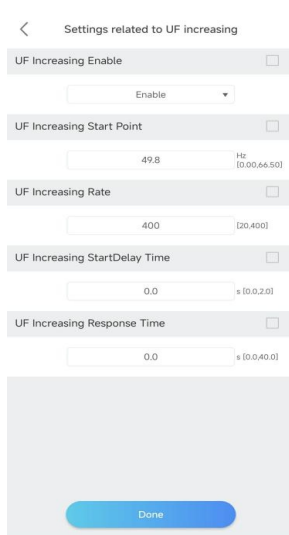

➤ **Grid Reconn Wait Time**

Tap Control > Safety parameter setting > Grid Reconn Wait Time; You can set Grid Reconn Wait Time.

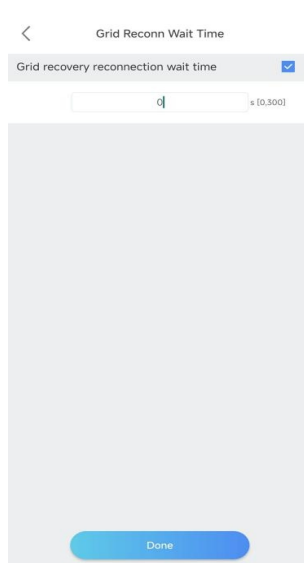

➤ **Frequency change rate enable**

Tap Control > Safety parameter setting > Frequency change rate enable; You can set Frequency change rate enable.

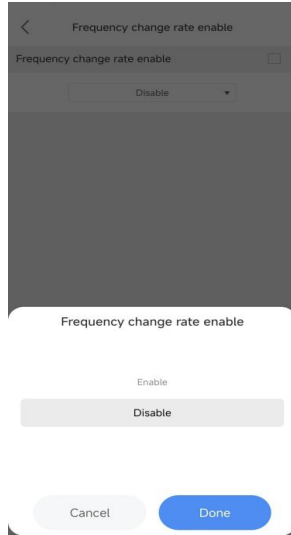

➤ **Set Inverter On/Off**

Tap Control > General settings > Set Inverter On/Off; you can power on/off the inverter, as the figure shows.

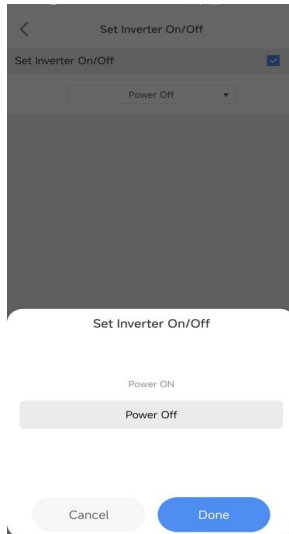

➤ **Set the Time of the Inverter**

Tap Control > General settings > Setting Time; you can set the local time, as the figure shows.

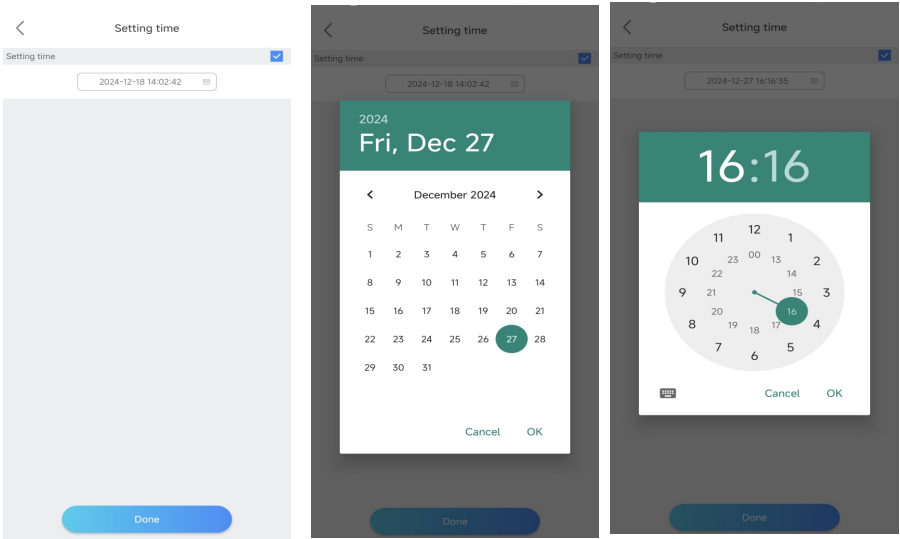

➤ **System Mode**

Tap Control > General settings > System Mode; you can set the System Mode, as the figure shows.

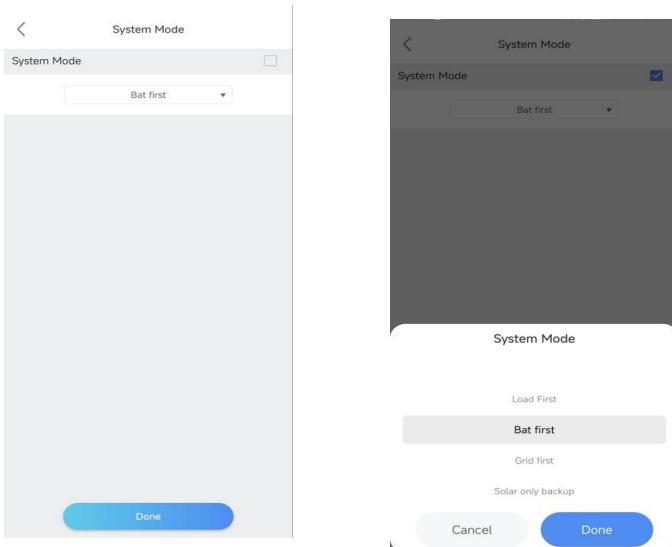

➤ **Set Reactive Power**

Tap Control>General settings> Set reactive power. You can set different reactive power modes; as the figure shows.

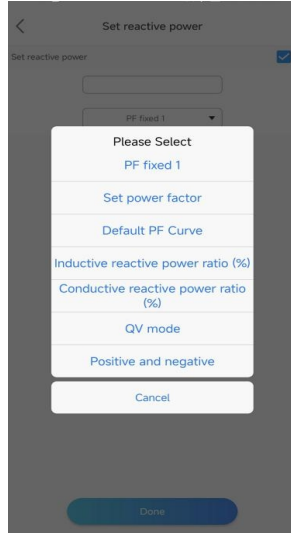
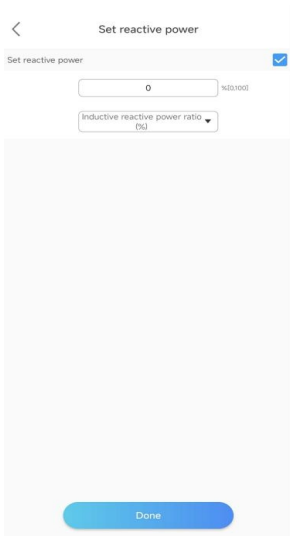

➤ **Enable the grid side electricity meter**

Tap Control > General settings > Enable the grid side electricity meter, you can Enable/Disable grid side electricity meter.

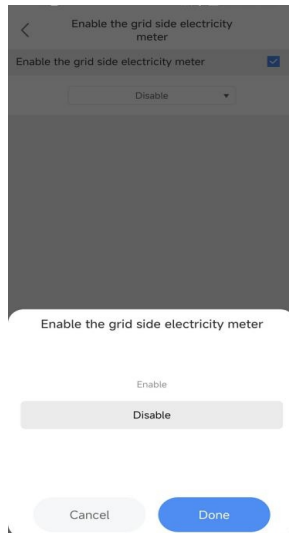
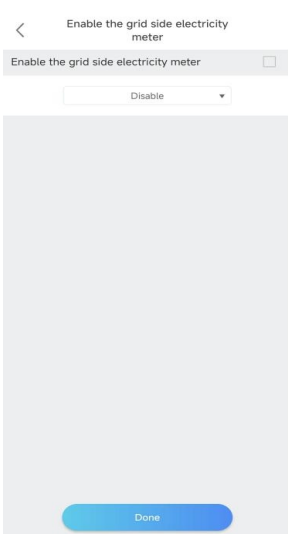

➤ Settings related to AC charging

Tap Control > General settings > Settings related to AC charging, You can set the parameters related to AC charging.

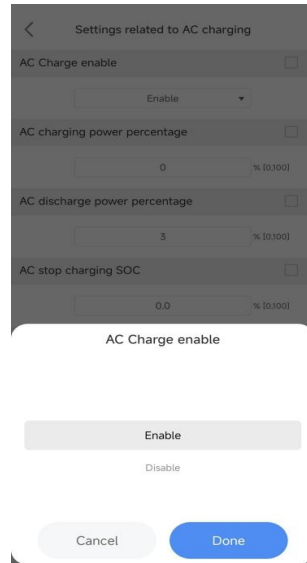
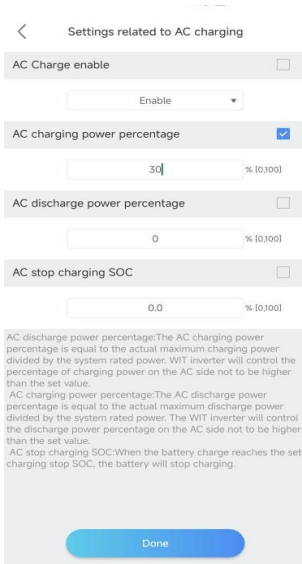

➤ Set the Battery Enable

Tap Control > Battery Setting > BMS1/BMS2/BMS3 Enabled, you can enable/disable Battery_1, Battery_2 and Battery_3, as the figure shows.

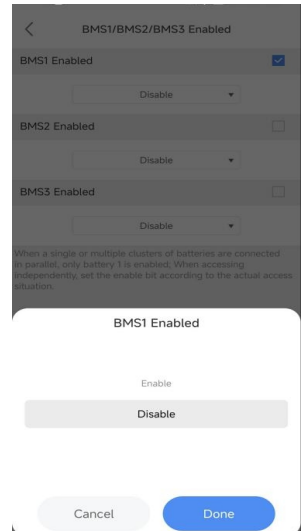
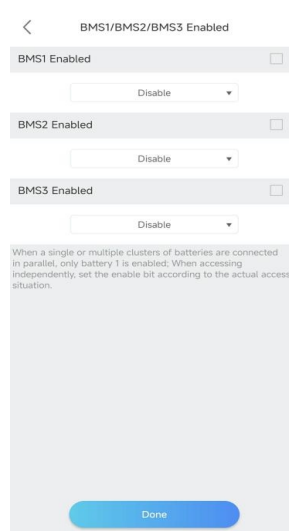
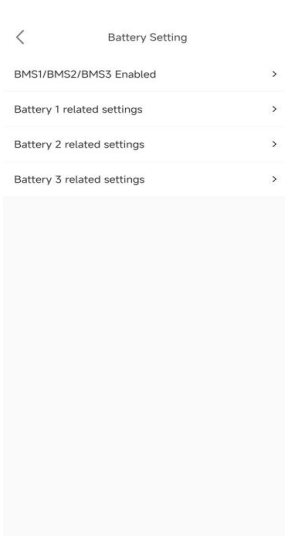

➤ Set the Battery

Tap Control > Battery Setting > Battery 1 related settings, you can set the Battery related parameters (the battery capacity, ranging from 0 to 290Ah; the maximum charging/discharging power, ranging from 0 to 15kw; the maximum charging/discharging current, ranging from 0 to 200A; the battery maximum charging voltage, ranging from 40 V to 60V; the battery discharge cutoff voltage, ranging from 0 V to 40V), as the figure shows.

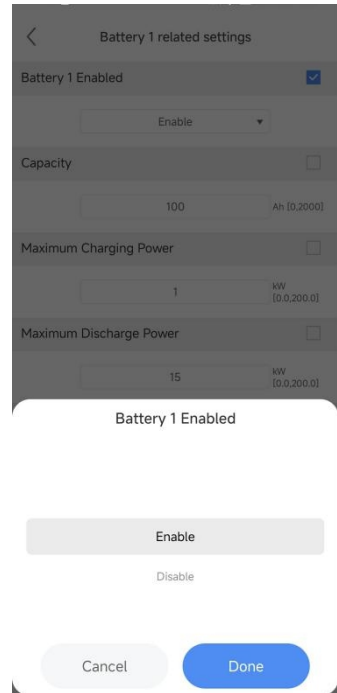
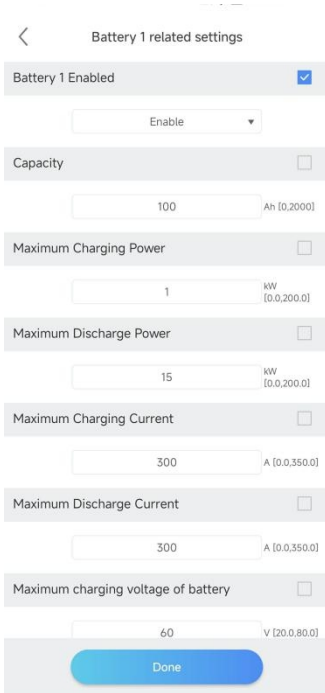

➤ Set the Off grid parameter settings

Tap Control > Off grid parameter settings > Related settings for grid connection and off grid. Two options are available: Automatic mode and Manual mode. If the Manual mode is selected, you can set the inverter to work in the on- /off-grid, or generator mode, as the figure shows. The Automatic Mode is recommended.as the figure shows.

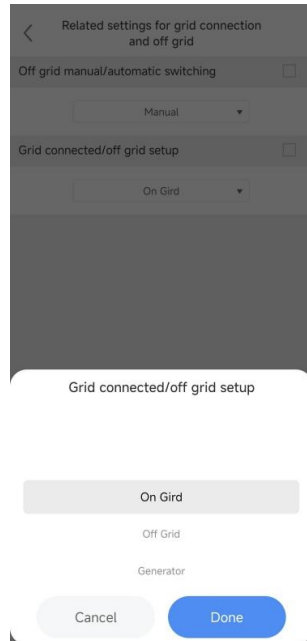
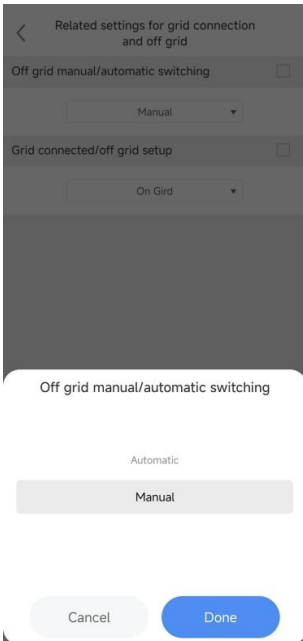
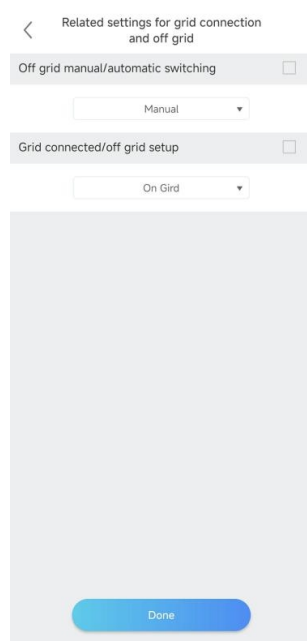
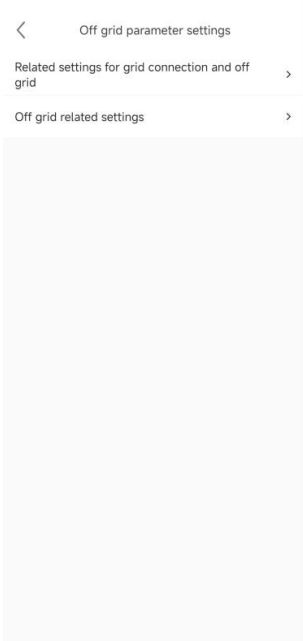

➤ **Set the Off grid related settings**

Tap Control > Off grid parameter settings > Off grid Related Setting, you can enable/disable the off-grid mode, set the off-grid frequency (50Hz/60Hz) and the off-grid voltage (220V/230V/ 240V/277V/127V), complying with the safety regulations.as the figure shows.

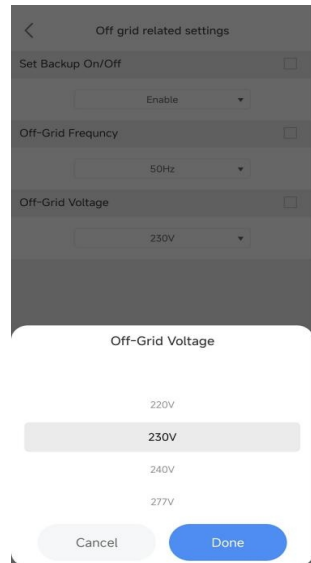
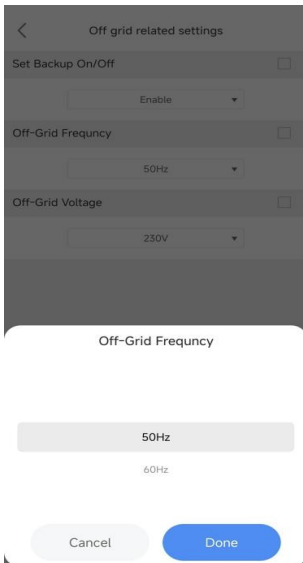
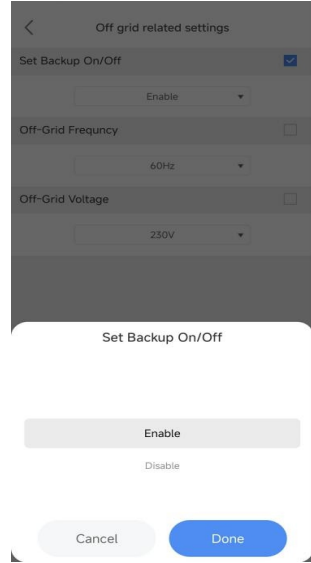

➤ **Single machine anti backflow setting**

Tap Control > Single machine anti backflow setting > Single machine anti backflow related settings, You can Enable/Disable the Single machine anti backflow function.

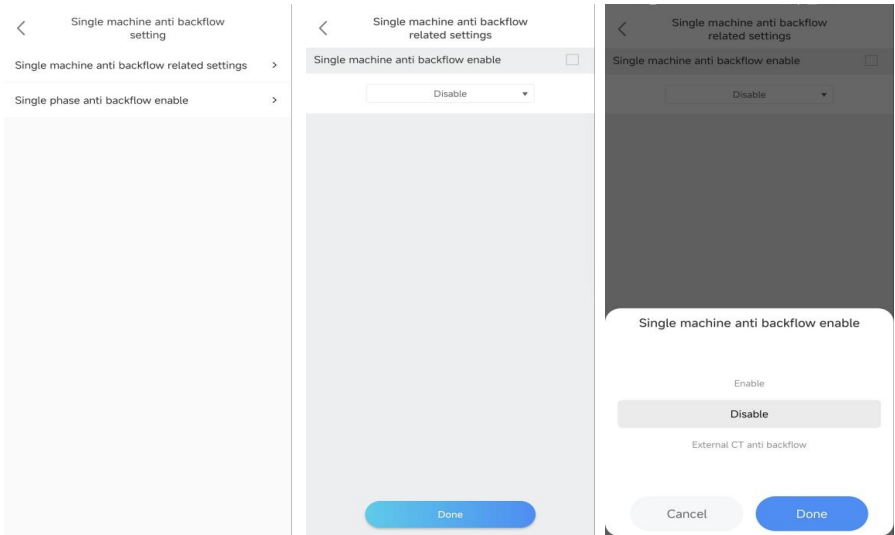

➤ **Set the Single phase Export Limitation**

Tap Control > Single machine anti backflow setting > Single phase anti backflow enable, you can enable/disable the Single phase anti backflow function, as the figure shows.

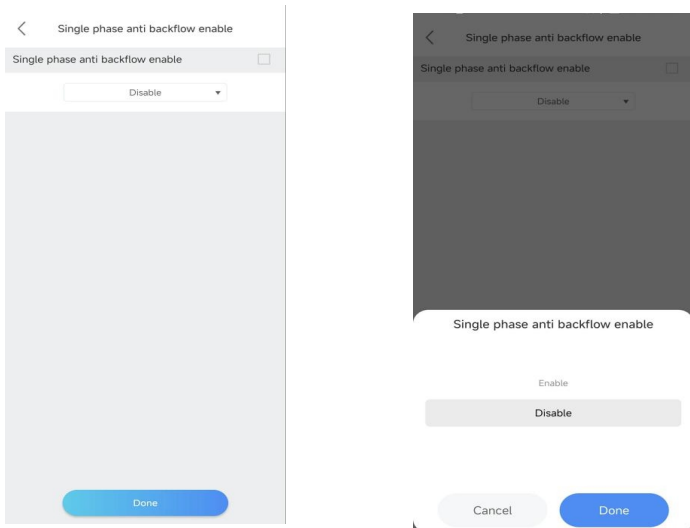

➤ **Set the Maximum spontaneous self use**

Tap Control > Advanced > Maximum spontaneous self use, you can enable/disable the Maximum spontaneous self use function, as the figure shows.

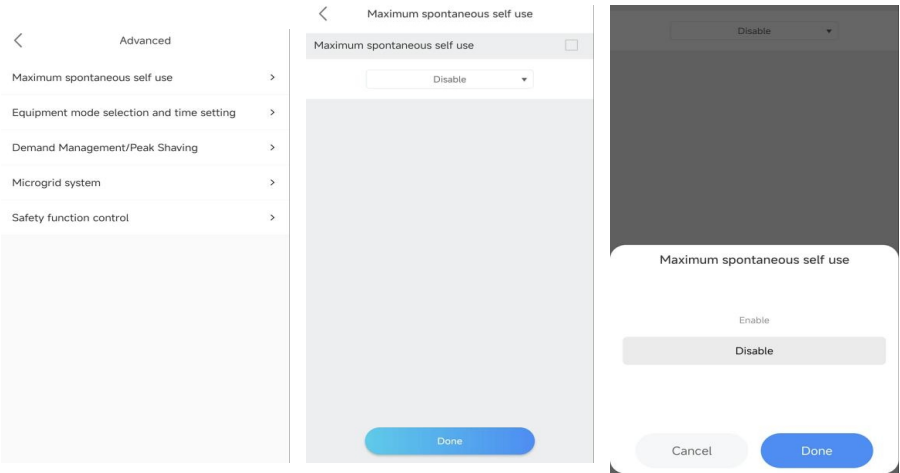

➤ **Equipment mode selection and time setting**

Tap Control > Advanced > Equipment mode selection and time setting; 6 time segments are configurable. You can set the start and end time of each period, the corresponding working mode, including Load First, Battery First and Grid First, solar only backup, IDLE/Charge From Clipped Solar, PTO and ECO., and whether to enable/disable the selected working mode. Choose the appropriate working mode considering the corresponding electricity rates and power consumption during the specific time period.

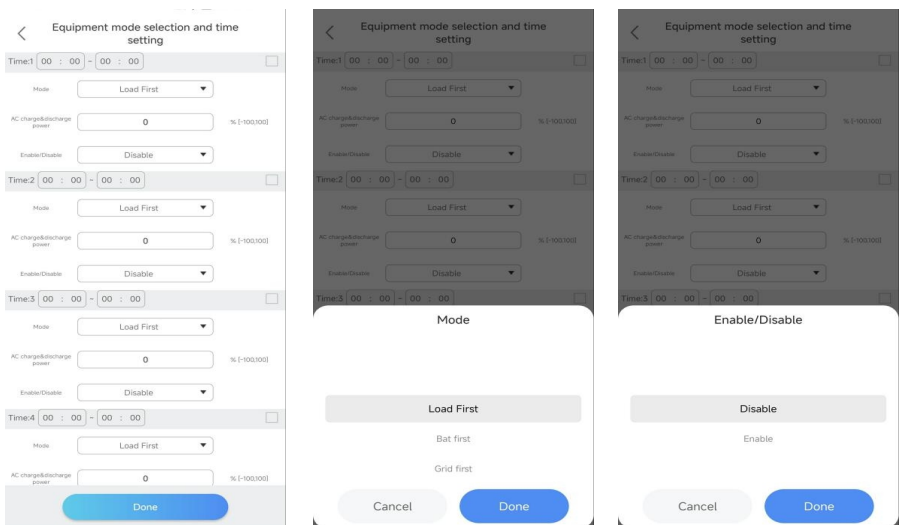

➤ **Demand Management/Peak Shaving**

Tap Control > Advanced > Demand Management/Peak Shaving, you can enable/disable the Demand Management Enablement

Function、Peak Shaving Backup SOC Enable Function and setting PeakinShaving Backup SOC, as the figure shows.

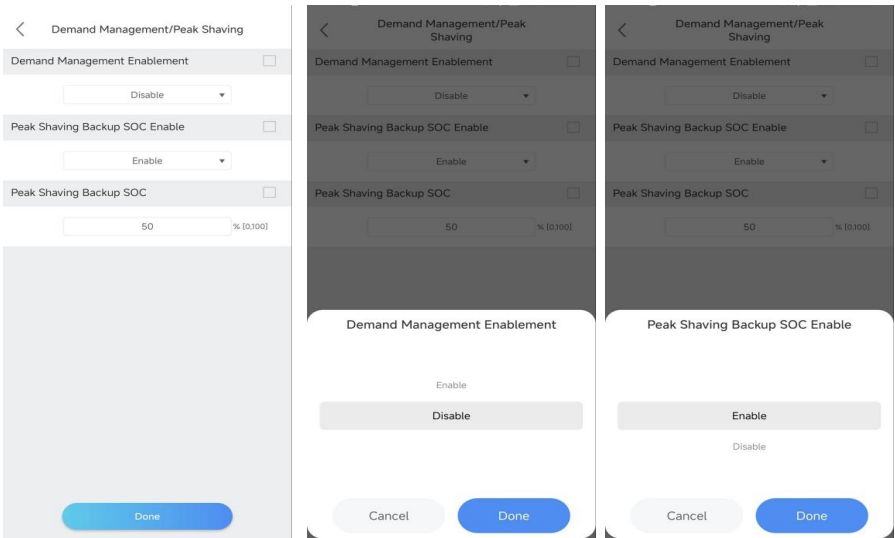

➤ **Microgrid system**

Tap Control > Advanced > Microgrid system, you can select Types of Access for GEN Port Devices , include “Generator” 、 “PV inverter” and “Smart Load” ; Enable/Disable Generator Enable; Generator Rating, ranging from 0 to 1000kW; Off grid oil engine startup SOC, ranging from 0 to 100%; Off grid oil engine stops SOC. ranging from 0 to 100%; Heat up time, ranging from 0 to 3600s; Power limit for oil engine charging, ranging from 0 to 1000kW;

Microgrid system

Types of Access for GEN Port Devices

Generator

Generator Enable

Disable

Generator Rating

50.0 kW [0.0,1000.0]

Off grid oil engine startup SOC

48 % [0,100]

Off grid oil engine stops SOC

60 % [0,100]

Heat up time

-1 s [0,3600]

Power limit for oil engine charging

-1 kW

Done

Microgrid system

-1 s [0,3600]

Power limit for oil engine charging

-0.1 kW [0.0,1000.0]

Electricity Meter 2 Enable

Disable

AC CoupleEnable

Enable

AC Couple Charging Start SOC

-1 % [0,100]

AC Couple Charging Stop SOC

-1 % [0,100]

SOC under secondary load

-1 % [0,100]

Done

Microgrid system

Types of Access for GEN Port Devices

Generator

Generator Enable

Disable

Generator Rating

50.0 kW [0.0,1000.0]

Off grid oil engine startup SOC

48 % [0,100]

Types of Access for GEN Port Devices

Generator

PV Inverter

Smart Load

Cancel Done

Microgrid system

Types of Access for GEN Port Devices

Generator

Generator Enable

Disable

Generator Rating

50.0 kW [0.0,1000.0]

Off grid oil engine startup SOC

48 % [0,100]

Generator Enable

Enable

Disable

Cancel Done

➤ **Safety function control**

Tap Control > Advanced > Safety function control, you can Enable/Disable Low voltage crossing etc.

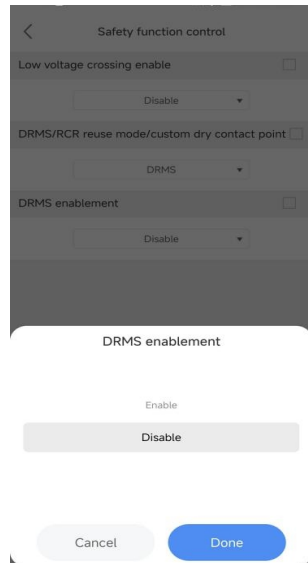
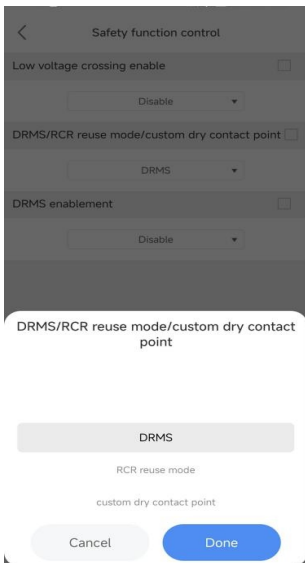
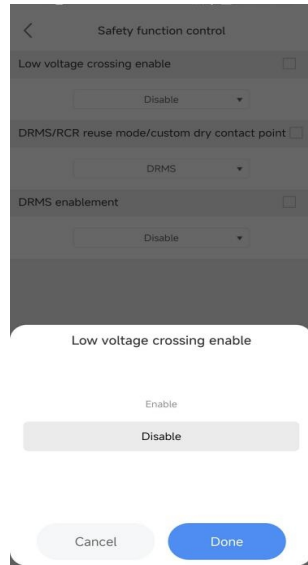
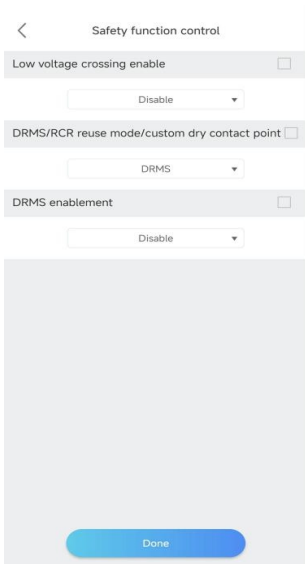

➤ **Parallel parameter setting**

Tap Control > Advanced > Parallel parameter setting, you can Enable/Disable Parallel parameter setting.

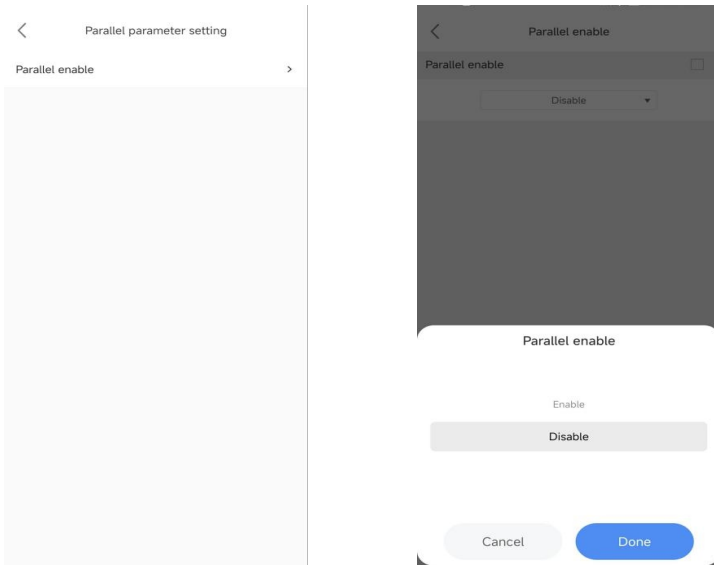

(6) On the "Edit" screen, you can change the device name as the figure shows.

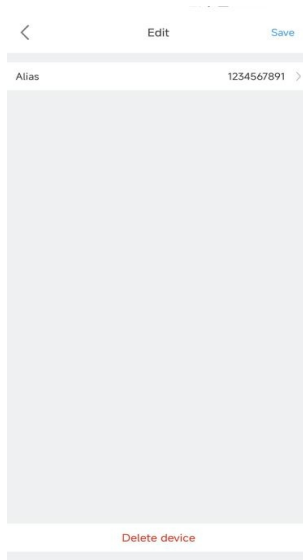

3. GroHome: displays the home energy system, including four sections: "PV linkage", "My device list", "My room" and "My scene"

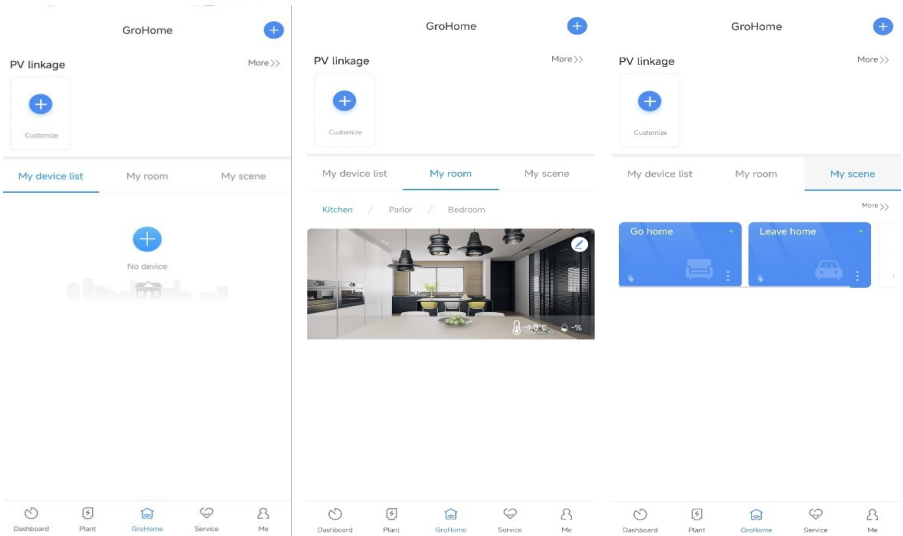

4. Service: includes the common faults and troubleshooting suggestions, as shown in the figure below. Should you encounter any problem about our product, you can contact the Growatt after-sales support or refer to the related documents

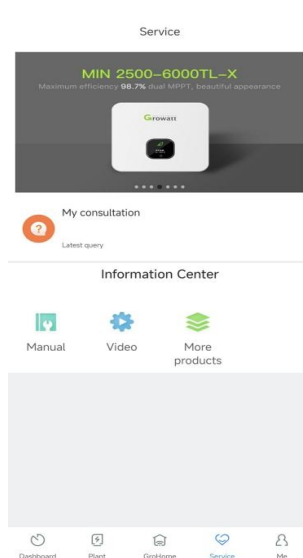

5. Me: You can check the account information, configure the datalogger or view notifications, as shown in the figure below.

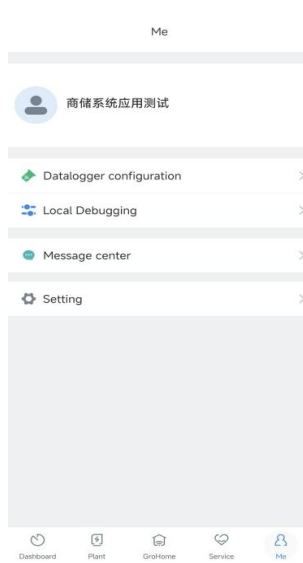

8.1.3 Remote Monitoring on the ShineServer Webpage

1. Open the browser, then enter <https://server.growatt.com/login?lang=en> in the address box to access the login page. Click “Register an Account” if you do not have an account.

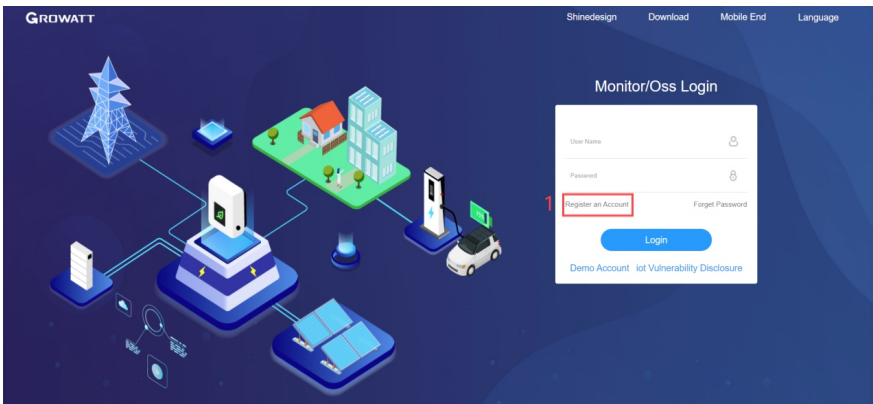

2. After the Registration Page is displayed, fill in the information as required and click to agree to the Privacy Policy. Fields marked with the “.” icon are mandatory. Click next, it will bring you to the “Add Plant” page. Then click “Back to Login” on the top right corner.

The screenshot shows the GROWATT Register page. At the top left is the GROWATT logo and the word 'Register'. At the top right is a 'Back to Login' link. The main content area has a header with '2' and three tabs: 'User' (selected), 'Installer', and 'Distributor'. Below the tabs is a registration form with the following fields: Country (dropdown), User Name (text, with a red dot indicating a mandatory field and a note 'No More than 30 Characters'), Password (text, with a red dot and a note 'Not less than 6 Digits'), Confirm Password (text, with a red dot and a note 'Not less than 6 Digits'), Language (dropdown, set to English), Phone Number (text), E-Mail (text), and Installer Code (text). At the bottom of the form is a checkbox labeled '3' with the text 'I have read and agree to the (Privacy Policy)', which is checked. Below the checkbox is a blue 'Next' button labeled '4'.

The screenshot shows the GROWATT Register page at the 'Please Fill in the Plant Information' step. At the top left is the GROWATT logo and the word 'Register'. At the top right is a '5 Back to Login' link. The main content area has a header with 'Please Fill in the Plant Information' and a 'Skip' link. Below the header are two tabs: 'Residential Plant' (selected) and 'Commercial Plant'. The form includes the following fields: Plant Type (dropdown, set to Ground-Mounted Plants), Plant Name (text, with a red dot and a note 'Please Enter Plant Name!'), Installation Date (text), Time Zone (dropdown, set to UTC +8), Map Selection (button with a location pin icon), Please Fill in the Plant Information (text, with a dropdown set to Singapore and a note 'Please Enter The Full Address'), PV Total Capacity (KWp) (text), and Selling Price (text, with a dropdown set to RMB/). At the bottom of the form is a blue 'Next' button.

3. On the Login screen, enter the username and the password to log in to the home screen.

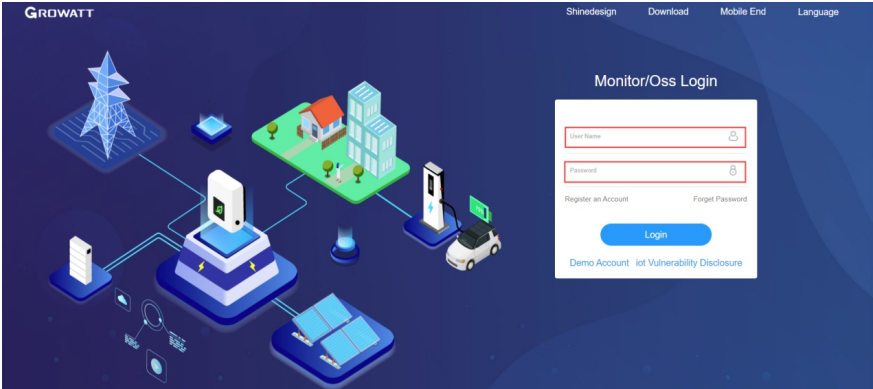

4. After accessing the home screen, the “Add Plant” window will pop up. Fill in the information as required (marked with “.”) and click “Yes”. If the plant has been created, you can select the target plant on the home screen.

Installation Information

Plant Type: Residential Plant
 Installation Date:
 PV Total Capacity(kWp):
 Installer:
 Plant Name: Example: David 6.24kWp Plant
 Temperature type: Centigrade(°C) Fahrenheit(°F)

Location Information

Country: Please Select
 City:
 Address:
 Time Zone: UTC -12
 Longitude:
 Latitude:
 Plant Image: (Only support JPG, PNG, JPEG, BMP, the size of no more than 5M)
 Microinverter Installation Map: (Only support JPG, PNG, JPEG, BMP, the size of no more than 5M)

Set Revenue Formula(Set 1Kwh As The Conversion Standard)

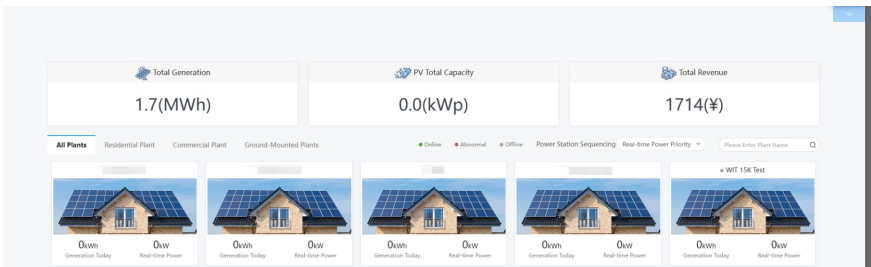

5. Click the target plant and the detailed page will be displayed, click “Add Data Logger” on the upper right corner to add the datalogger connected to the inverter.

1) Enter the serial number (SN) of the datalogger.

2) Select the target power plant. You might need to enter the verification code of the datalogger as prompted.

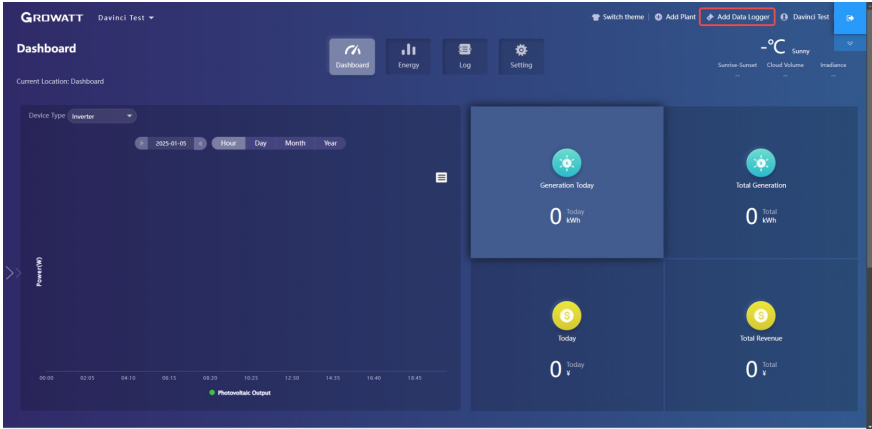

Data Logger SN

Data Logger Check Code

Assigned Plant

Yes

Cancel

6. After adding the datalogger successfully, you can click Dashboard to view details about related devices.

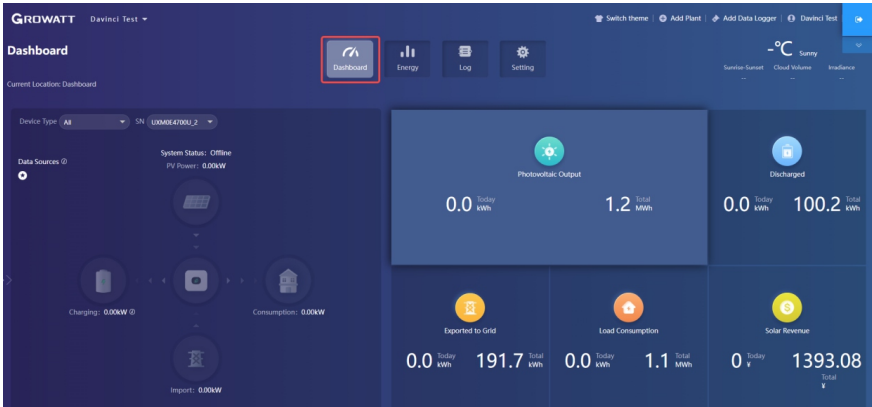

Dashboard: 1. Running status and energy display

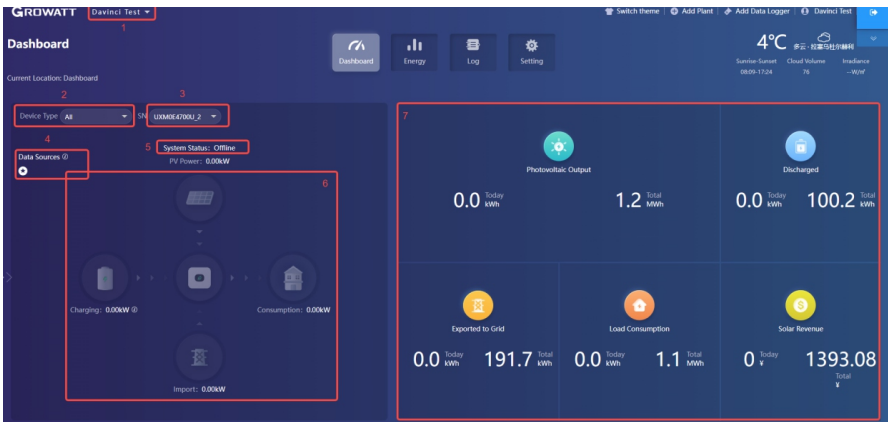

- 1) Plant List: select the target plant from the drop-down list
- 2) Device Type: Select the device from the drop-down list
- 3) Input/Search Number: Upon the initial search, enter the serial number of the specific device; if you have searched for it before, you can select the device from the drop-down list
- 4) Data Sources: displays the data source of the selected device: Load First, Battery First and Grid first.
- 5) System Status: displays the running status of the selected device: operating, faulty, standby and off-line
- 6) System Running Graph: displays the power flow between the PV modules, the battery, the generator and the AC side
- 7) Energy: displays today's/total PV generation, power imported from grid, power exported to the grid and the load consumption

2. Energy Trend

- 1) System Production: displays the power for self-consumption and the power exported to the grid
- 2) Date: select a specific date, you can view the energy data in a specific period, day, month or year
- 3) Load Consumption: displays the power for self-consumption and the power drawn from the grid
- 4) Display options: to show/hide the content by clicking the corresponding color circle. By placing the cursor on the specific color circle for a long period, it will display the energy trend of the selected item only

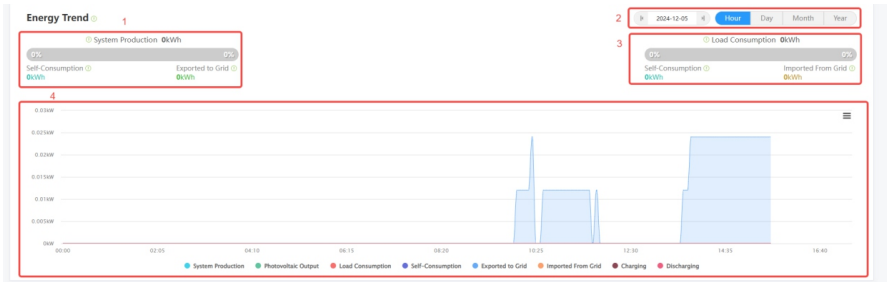

3. Battery Information

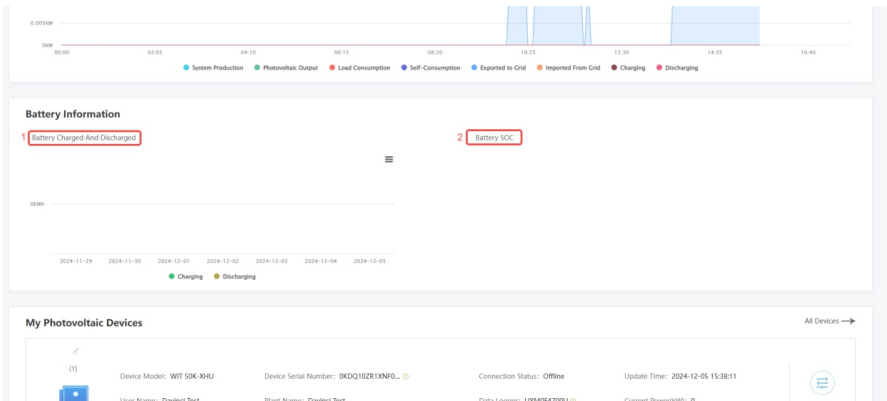

- 1) Battery charge and discharge information over the last seven days: it can display the charge and discharge history of the battery clusters over the past seven days.
- 2) Battery rack daily SOC information: displays the battery SOC.

4. My PV devices

This section displays all devices involved in the selected PV plant (online devices are shown first, followed by offline devices).

Energy

1. Parameter comparison

The screenshot shows the 'Energy' section of the Growatt dashboard. The 'Parameter Comparison' tab is active. A search bar is at the top left. Below it, the current location is 'Energy > Parameter Comparison'. The interface includes a date selector (2024-12-05) and a filter dropdown (WIT). A list of device IDs is on the left, and a large empty chart area is on the right. Red boxes and numbers 1, 2, and 3 highlight the device type, date, and chart area respectively.

- 1) Device type: Select the device type for comparison, such as the WIT inverter or the meter.
- 2) Date: select a specific date, you can view the energy data in a specific period, day, month or year.
- 3) Power curve: Show the power curve of the machine operation.

2. Plant Management

The screenshot shows the 'Energy' section of the Growatt dashboard. The 'Plant Management' tab is active. The interface shows a table with columns for No., Plant Name, Country, City, Installation Date, Time Zone, PV Total Capacity(kWp), Total Power Generation(kWh), and Operations. The table contains four rows of data. Red boxes and numbers 1 and 2 highlight the 'Edit' and 'Delete' icons in the Operations column respectively.

No.	Plant Name	Country	City	Installation Date	Time Zone	PV Total Capacity(kWp)	Total Power Generation(kWh)	Operations
1	Davinci Test	China		2023-07-13	8	0	0	
2	Davinci Test 1	China		2023-07-13	8	0	0	
3	RH	Australia		2023-10-16	1	0	0	
4	WIT SIK TEST	Thailand		2024-12-06	-12	0	1395.5	

Click Plant Management and you can view all PV plants associated with the current account.

- 1) Edit: Click the "Edit" icon (indicated in the figure above) to modify the PV plant information
- 2) Delete: Click the "Delete" icon (indicated in the figure above) to delete the selected PV plant
- 3) Data: Click the "Data" icon (indicated in the figure above) to view the energy yield and power of the selected plant

Log

On the Log page, you can view the error code and the fault description.

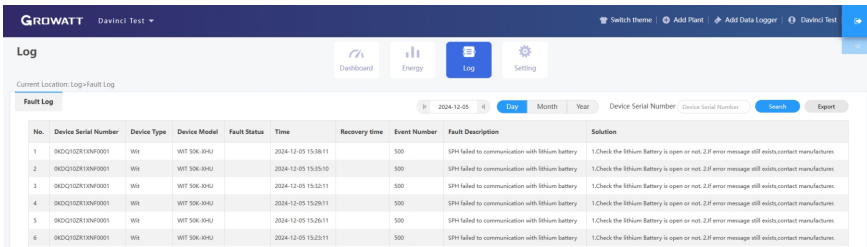

The screenshot shows the GROWATT Log page. At the top, there are navigation tabs for Dashboard, Energy, Log (selected), and Setting. Below the tabs, the current location is 'Log > Fault Log'. There are filters for '2024-12-05', 'Day', 'Month', 'Year', 'Device Serial Number', and 'Device Serial Number'. A search bar and an 'Export' button are also present. The main content is a table with the following columns: No., Device Serial Number, Device Type, Device Model, Fault Status, Time, Recovery time, Event Number, Fault Description, and Solution.

No.	Device Serial Number	Device Type	Device Model	Fault Status	Time	Recovery time	Event Number	Fault Description	Solution
1	0K0102813NF0001	WR	WIT 50K-304J		2024-12-05 15:38:11		500	SFH failed to communication with lithium battery	1.Check the lithium Battery is open or not. 2.If error message still exists,contact manufactures.
2	0K0102813NF0001	WR	WIT 50K-304J		2024-12-05 15:53:10		500	SFH failed to communication with lithium battery	1.Check the lithium Battery is open or not. 2.If error message still exists,contact manufactures.
3	0K0102813NF0001	WR	WIT 50K-304J		2024-12-05 15:52:11		500	SFH failed to communication with lithium battery	1.Check the lithium Battery is open or not. 2.If error message still exists,contact manufactures.
4	0K0102813NF0001	WR	WIT 50K-304J		2024-12-05 15:58:11		500	SFH failed to communication with lithium battery	1.Check the lithium Battery is open or not. 2.If error message still exists,contact manufactures.
5	0K0102813NF0001	WR	WIT 50K-304J		2024-12-05 15:56:11		500	SFH failed to communication with lithium battery	1.Check the lithium Battery is open or not. 2.If error message still exists,contact manufactures.
6	0K0102813NF0001	WR	WIT 50K-304J		2024-12-05 15:52:11		500	SFH failed to communication with lithium battery	1.Check the lithium Battery is open or not.2.If error message still exists,contact manufactures.

Setting

1. Account management

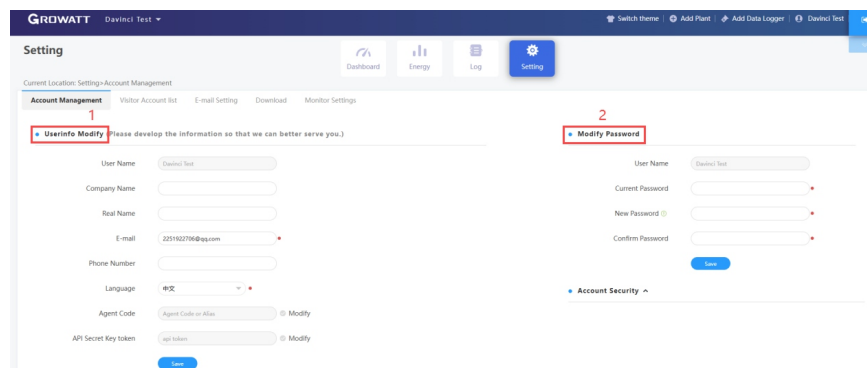

The screenshot shows the GROWATT Setting page, specifically the Account Management section. The page has navigation tabs for Account Management, Visitor Account list, E-mail Setting, Download, and Monitor Settings. The Account Management tab is selected. There are two main sections: 'Userinfo Modify' (labeled with a red '1') and 'Modify Password' (labeled with a red '2').

Userinfo Modify: This section contains input fields for User Name, Company Name, Real Name, E-mail, Phone Number, Language, and Agent Code. There are also buttons for 'Agent Code or Alias' and 'API Secret Key Idem'.

Modify Password: This section contains input fields for User Name, Current Password, New Password, and Confirm Password. There is a 'Save' button.

1) Modify your account information

2) Change the password: you can change the password on this page

2. Download

A range of documents are available for download.

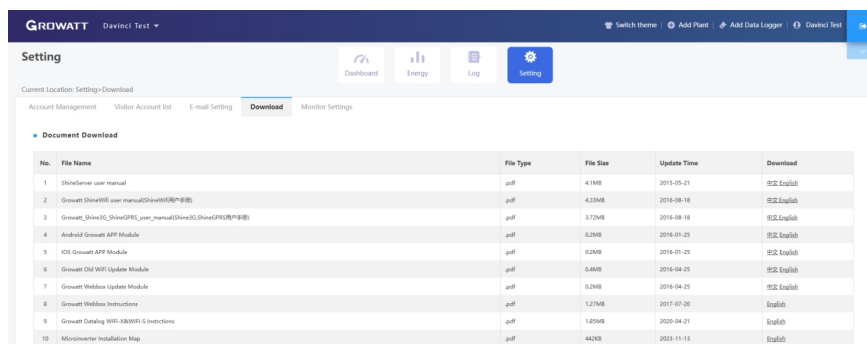

The screenshot shows the GROWATT Setting page, specifically the Download section. The page has navigation tabs for Account Management, Visitor Account list, E-mail Setting, Download (selected), and Monitor Settings. The Download section is titled 'Document Download' and contains a table with the following columns: No., File Name, File Type, File Size, Update Time, and Download.

No.	File Name	File Type	File Size	Update Time	Download
1	ShineServer user manual	pdf	4.1MB	2018-05-21	中文-English
2	Growatt ShineWiFi user manual(ShineWiFi用户手册)	pdf	4.33MB	2018-08-18	中文-English
3	Growatt_ShineWi-Fi_ShineWiFi_user_manual(ShineWi-Fi用户手册)	pdf	3.72MB	2018-08-18	中文-English
4	Android Growatt APP Module	pdf	0.24M	2016-01-25	中文-English
5	iOS Growatt APP Module	pdf	0.24M	2016-01-25	中文-English
6	Growatt OM WiFi Update Module	pdf	0.40M	2016-04-25	中文-English
7	Growatt Wireless Update Module	pdf	0.24M	2016-04-25	中文-English
8	Growatt Wireless Instructions	pdf	1.27MB	2017-07-30	English
9	Growatt Detailing W99-100W99-1 Instructions	pdf	1.85MB	2020-04-21	English
10	Microinverter Installation Map	pdf	442KB	2020-11-13	English

Device

1. Datalogger

The screenshot shows the GROWATT Device Datalogger interface. At the top, there are navigation tabs for Dashboard, Energy, Log, and Setting. Below this, there are three main sections: Power, Generation, and Revenue. The Power section shows Current Power (0) and Rated Power (1355). The Generation section shows Generation Today (290.7), This Month (336.1), and Total Generation (598358.5). The Revenue section shows Today (348.84), This Month (403.32), and Total Revenue (718030.25). Below these sections, there is a Data Logger section with a search bar and a list of devices. The first device is GPG0DBJ1FG, and the second is GPG0DBJ1T2. The interface includes numbered callouts 1 through 10 pointing to various fields and buttons.

- 1) Serial number: each datalogger has a specific SN, which can be used to search for the device;
- 2) User name and the PV plant to which the datalogger is connected;
- 3) Connection status: connected or disconnected;
- 4) Data update interval;
- 5) Device type;
- 6) Type of equipment;
- 7) Firmware version;
- 8) Enter the serial number to search for the target datalogger;
- 9) Add a datalogger: enter the serial number to add the datalogger;
- 10) Datalogger settings: you can set the update time for the datalogger.

2. WIT

The screenshot shows the GROWATT Device WIT interface. At the top, there are navigation tabs for Dashboard, Energy, Log, and Setting. Below this, there are three main sections: Power, Generation, and Revenue. The Power section shows Current Power (0) and Rated Power (1355). The Generation section shows Generation Today (10.8), This Month (45.4), and Total Generation (598067.8). The Revenue section shows Today (12.96), This Month (54.48), and Total Revenue (717681.38). Below these sections, there is a Data Logger section with a search bar and a list of devices. The first device is JKN06C0T2, and the second is JKN07Q064. The interface includes numbered callouts 1 through 10 pointing to various fields and buttons.

- 1) Enter the serial number to find the device;
- 2) Device model;
- 3) User name and the PV plant to which the device is connected;
- 4) Daily and monthly energy yield;
- 5) Serial number of the selected device;
- 6) Operating status: operating, standby, disconnected or faulty;
- 7) Serial number of the datalogger connected to the device;
- 8) Rated power;
- 9) Current power;
- 10) Parameter settings.
- 10.1) Setting of safety parameters, including 1st, 2nd and 3rd order underfrequency point, overfrequency point, undervoltage point and overvoltage point.

• Setting
✕

Data Logger: JKN0E8T01G

Property: YE1.0/YEaa050499/ZDda-0006/S21B0CD00T33P0FU01M0096

Command Read

Regulation parameter setting ▲

UV1/UV2/UV3 Frequency ▲

<input type="radio"/> UV1 Frequency ⓪	<input style="width: 80%;" type="text" value="47.5"/>	[45.00,50.00]Hz
<input type="radio"/> UV2 Frequency ⓪	<input style="width: 80%;" type="text" value="47.5"/>	[45.00,50.00]Hz
<input type="radio"/> UV3 Frequency ⓪	<input style="width: 80%;" type="text" value="47.5"/>	[45.00,50.00]Hz

OV1/OV2/OV3 Frequency ▲

<input type="radio"/> OV1 Frequency ⓪	<input style="width: 80%;" type="text" value="50.5"/>	[50.00,55.00]Hz
<input type="radio"/> OV2 Frequency ⓪	<input style="width: 80%;" type="text" value="50.5"/>	[50.00,55.00]Hz

Please Enter Password

Yes

Advanced Setting

Cancel

Setting ✕

UV3 Frequency 47.0 [45.00,50.00]Hz

OV1/OV2/OV3 Frequency ▲

OV1 Frequency 52.0 [50.00,55.00]Hz

OV2 Frequency 52.0 [50.00,55.00]Hz

OV3 Frequency 52.0 [50.00,55.00]Hz

UV1/UV1/UV1 Voltage ▲

UV1 Voltage 338.6 [17.3,762.0]V

UV2 Voltage 79.7 [17.3,762.0]V

UV3 Voltage 79.7 [17.3,762.0]V

OV1/OV2/OV3 Voltage ▲

Please Enter Password

Setting ✕

UV1 Voltage 338.6 [17.3,762.0]V

UV2 Voltage 79.7 [17.3,762.0]V

UV3 Voltage 79.7 [17.3,762.0]V

OV1/OV2/OV3 Voltage ▲

OV1 Voltage 438.2 [17.3,762.0]V

OV2 Voltage 458.1 [17.3,762.0]V

OV3 Voltage 517.9 [17.3,762.0]V

Grid related settings ▲

High Grid Voltage Limit 438.2 [17.3,762.0]V

Low Grid Voltage Limit 338.6 [17.3,762.0]V

Please Enter Password

10.2) High grid voltage limit (voltage upper threshold of grid connection).

Setting [X]

OV3 Voltage [17.3,762.0]V

Grid related settings ▲

High Grid Voltage Limit [17.3,762.0]V

Low Grid Voltage Limit [17.3,762.0]V

High Grid Frequency Limit [50.00,55.00]Hz

Low Grid Frequency Limit [45.00,50.00]Hz

Loading, restarting, and unloading rates ▲

Loading rate [1.0,6000.0]%

Restart loading rate [1.0,6000.0]%

Load reduction rate [1.0,6000.0]%

Please Enter Password

10.3) Low grid voltage limit (voltage lower threshold of grid connection).

Setting [X]

OV3 Voltage [17.3,762.0]V

Grid related settings ▲

High Grid Voltage Limit [17.3,762.0]V

Low Grid Voltage Limit [17.3,762.0]V

High Grid Frequency Limit [50.00,55.00]Hz

Low Grid Frequency Limit [45.00,50.00]Hz

Loading, restarting, and unloading rates ▲

Loading rate [1.0,6000.0]%

Restart loading rate [1.0,6000.0]%

Load reduction rate [1.0,6000.0]%

Please Enter Password

10.4) High grid frequency limit (frequency upper threshold of grid connection) .

The screenshot shows a 'Setting' dialog box with the following configuration:

Setting	Value	Range
OV3 Voltage	517.9	[17.3,762.0]V
Grid related settings ▲		
High Grid Voltage Limit	438.2	[17.3,762.0]V
Low Grid Voltage Limit	338.6	[17.3,762.0]V
High Grid Frequency Limit ⓘ	50.1	[50.00,55.00]Hz
Low Grid Frequency Limit ⓘ	49.5	[45.00,50.00]Hz
Loading, restarting, and unloading rates ▲		
Loading rate	300.0	[1.0,6000.0]%
Restart loading rate	300.0	[1.0,6000.0]%
Load reduction rate	-0.1	[1.0,6000.0]%

At the bottom of the dialog, there are four buttons: 'Please Enter Password', 'Yes', 'Advanced Setting', and 'Cancel'. The 'Yes' button is highlighted in blue.

10.5) Low grid frequency limit (frequency lower threshold of grid connection).

The screenshot shows the same 'Setting' dialog box as in 10.4, but with the 'Low Grid Frequency Limit' option selected and highlighted with a red box. The configuration is as follows:

Setting	Value	Range
OV3 Voltage	517.9	[17.3,762.0]V
Grid related settings ▲		
High Grid Voltage Limit	438.2	[17.3,762.0]V
Low Grid Voltage Limit	338.6	[17.3,762.0]V
High Grid Frequency Limit ⓘ	50.1	[50.00,55.00]Hz
Low Grid Frequency Limit ⓘ	49.5	[45.00,50.00]Hz
Loading, restarting, and unloading rates ▲		
Loading rate	300.0	[1.0,6000.0]%
Restart loading rate	300.0	[1.0,6000.0]%
Load reduction rate	-0.1	[1.0,6000.0]%

At the bottom of the dialog, there are four buttons: 'Please Enter Password', 'Yes', 'Advanced Setting', and 'Cancel'. The 'Yes' button is highlighted in blue.

10.6) Load, restart load, and down load rate settings.

Setting ✕

High Grid Frequency Limit ⓘ [50.00,55.00]Hz

Low Grid Frequency Limit ⓘ [45.00,50.00]Hz

Loading, restarting, and unloading rates ▲

Loading rate [1.0,6000.0]%

Restart loading rate [1.0,6000.0]%

Load reduction rate [1.0,6000.0]%

Settings related to OF derating ▲

Derating Start point(f) [0.00,66.50]Hz

Derating Gradient(f) [0,2000]

Over-frequency load reduction delay time [0.0,20.0]s

Please Enter Password

10.7) Setting the start point of overfrequency load shedding: Load shedding after higher than the set frequency.

Setting ✕

Settings related to OF derating ▲

Derating Start point(f) [0.00,66.50]Hz

Derating Gradient(f) [0,2000]

Over-frequency load reduction delay time [0.0,20.0]s

Over-frequency load reduction response time [0.0,40.0]s

Settings related to UF increasing ▲

UF Increasing Enable

UF Increasing Start Point [0.00,66.50]Hz

Under-frequency loading slope [20,400]

Under-frequency loading delay time [0.0,2.0]s

Please Enter Password

10.8) Set underfrequency loading enable: you can set whether to allow the underfrequency loading function to be enabled.

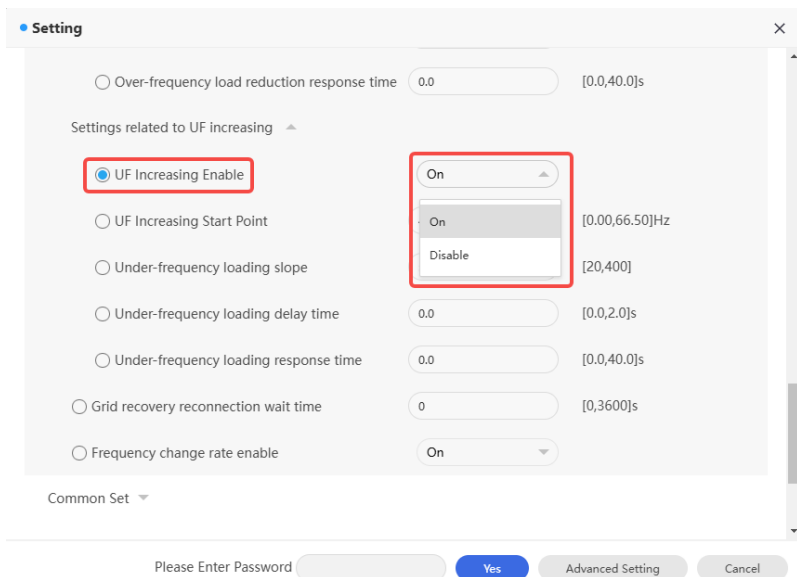

10.9) Set the frequency rate of change enable.

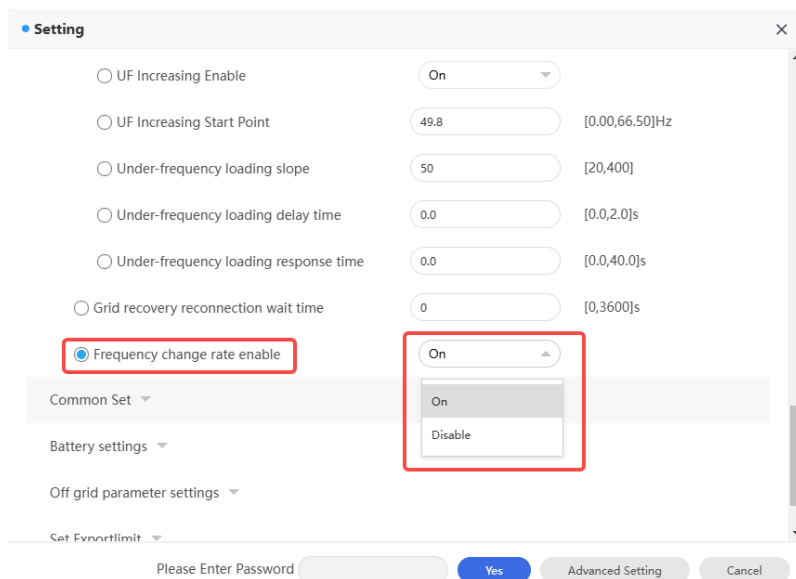

10.10) Powering on/off the device: you can power on/off the device remotely.

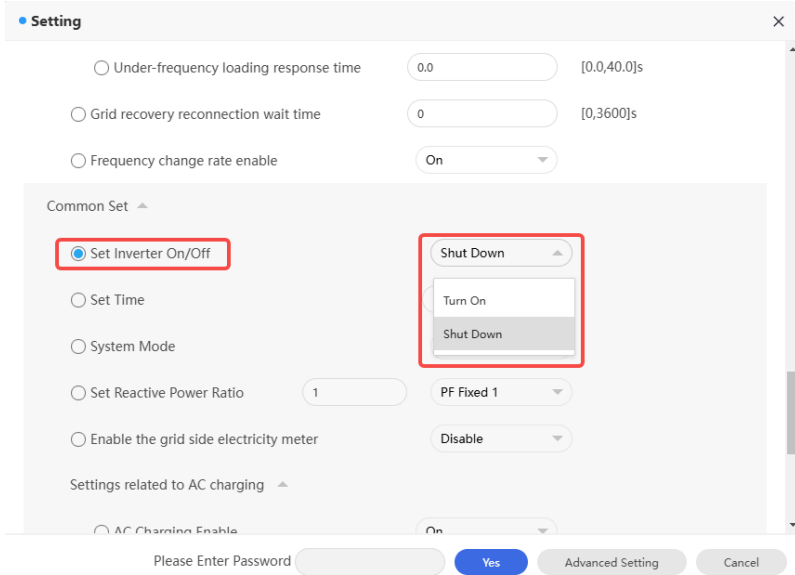

10.11) Set the time: you can set the time for the device.

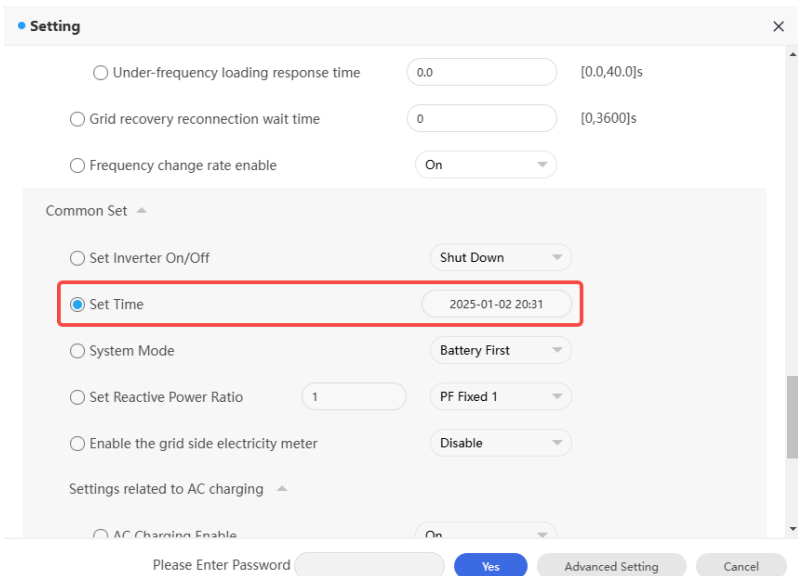

10.12) Setting the default working mode of the system: selecting the working mode according to the customer's needs, the working modes are Load Priority, Battery Priority, Grid Priority, Pure PV Energy Storage, Idle Grid Priority for Energy Storage, PTO, Grid Priority (ECO).

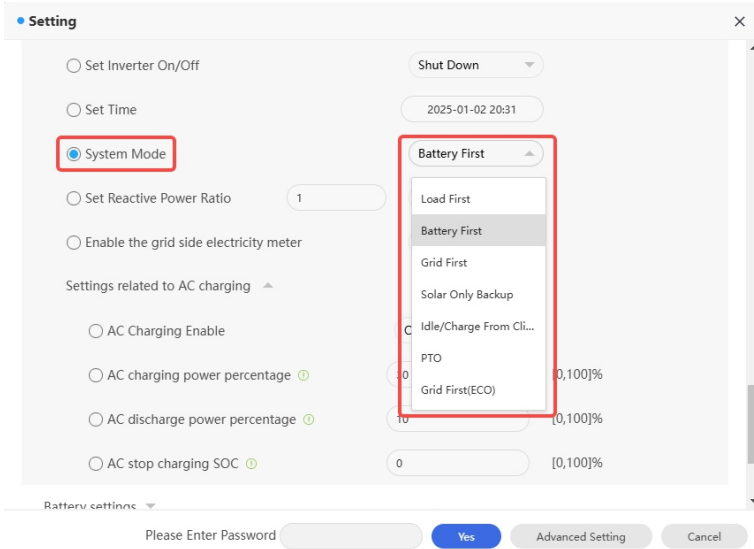

10.13) Setting the reactive power: The corresponding PF mode can be set.

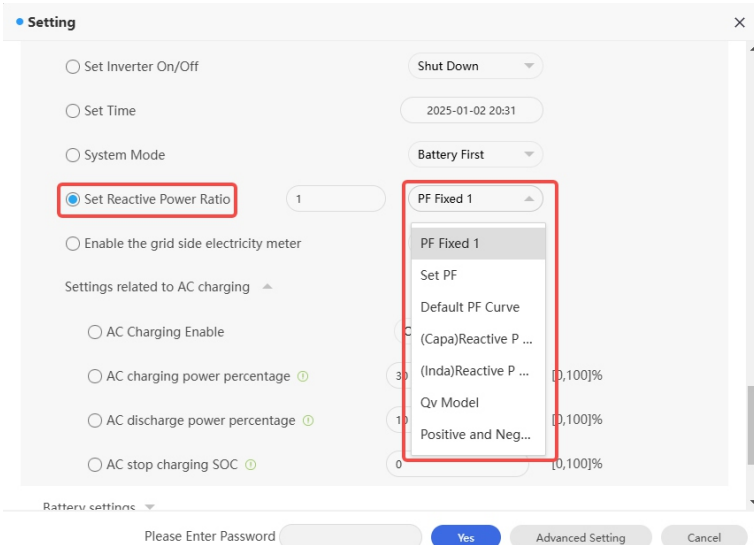

10.14) Setting the network side meter enable: you can choose whether to enable the network side meter function or not.

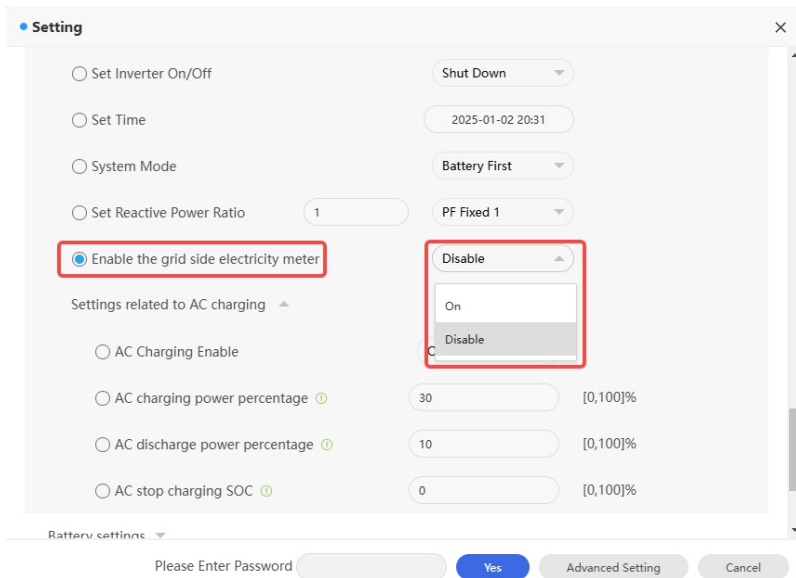

10.15) AC charging: you can set whether to enable the mains charging function or not.

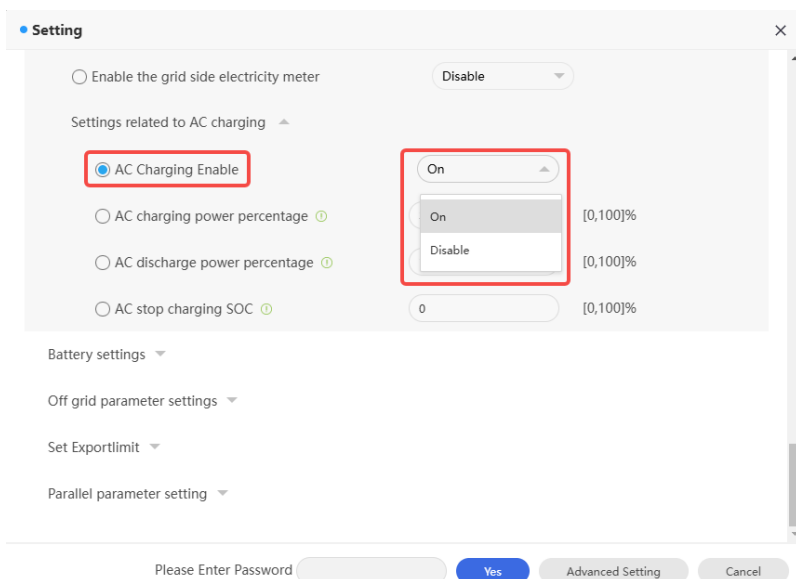

10.16) AC charge power: you can set the AC charge power.

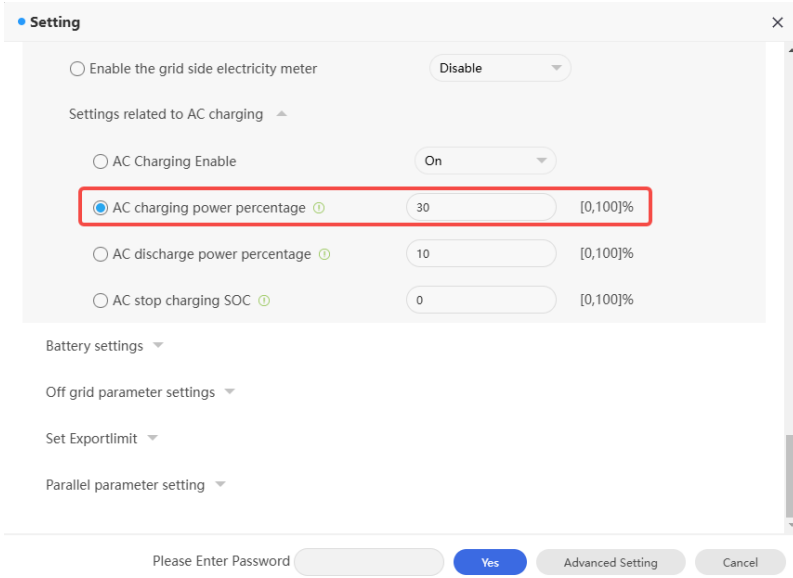

10.17) AC discharging power: you can set the AC discharge power.

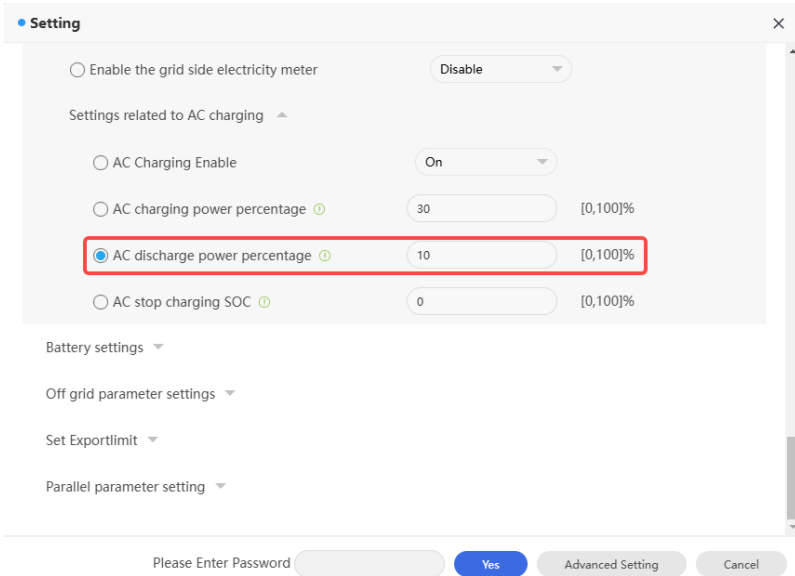

10.18) AC stop charging SOC: the battery charge cut-off SOC can be set (100 recommended).

The screenshot shows a 'Setting' window with a close button (X) in the top right. At the top, there is an option 'Enable the grid side electricity meter' with a radio button and a dropdown menu set to 'Disable'. Below this is a section 'Settings related to AC charging' with an expandable arrow. It contains four items: 'AC Charging Enable' (radio button, dropdown 'On'), 'AC charging power percentage' (radio button, input '30', range '[0,100]%'), 'AC discharge power percentage' (radio button, input '10', range '[0,100]%'), and 'AC stop charging SOC' (radio button, input '0', range '[0,100]%', highlighted with a red box). Below this are sections for 'Battery settings', 'Off grid parameter settings', 'Set Exportlimit', and 'Parallel parameter setting', each with a dropdown arrow. At the bottom, there is a 'Please Enter Password' field, a 'Yes' button, and 'Advanced Setting' and 'Cancel' buttons.

10.19) Discharge stop SOC: you can set the battery discharge cut-off SOC (recommended 10), the discharge cut-off SOC is divided into grid-connected discharge stop SOC and off-grid discharge stop SOC.

The screenshot shows a 'Setting' window with a close button (X) in the top right. It features a section 'Battery 1 related settings' with an expandable arrow. This section lists ten parameters: 'Capacity' (input '100', range '[0,2000]Ah'), 'Maximum Charging Power' (input '60.0', range '[0.0,200.0]kW'), 'Maximum Discharge Power' (input '60.0', range '[0.0, 200.0]kW'), 'Charge Max Current' (input '165.0', range '[0.0, 200.0]A'), 'Max Discharge' (input '165.0', range '[0.0, 200.0]A'), 'Maximum charging voltage of battery' (input '900.0', range '[200.0,900.0]V'), 'Discharge cut-off voltage' (input '200.0', range '[200.0,900.0]V'), 'Stop SOC when charging the battery' (input '100', range '[0,100]%'), 'Discharge Stopped Soc' (input '10', range '[0,99]%'), and 'Off grid cut-off SOC' (input '0', range '[0,99]%', highlighted with a red box). At the bottom, there is a 'Please Enter Password' field, a 'Yes' button, and 'Advanced Setting' and 'Cancel' buttons.

10.20) Enable Battery: You can choose to enable or disable battery.

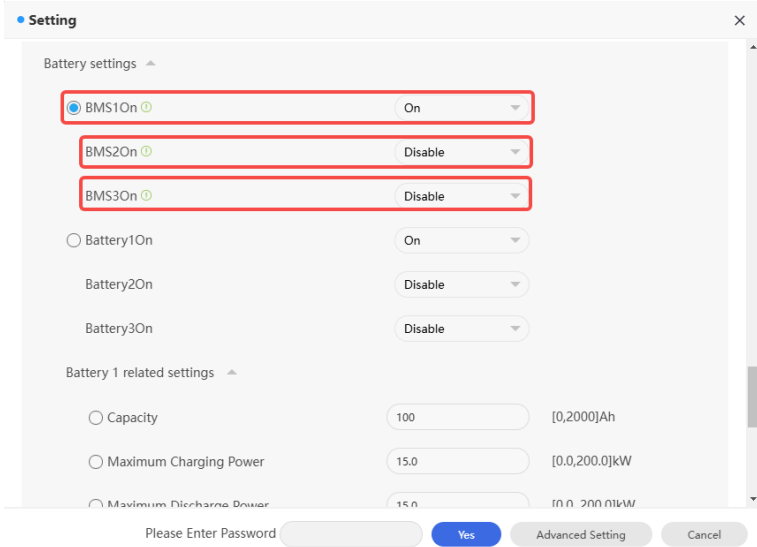

10.21) Battery Settings: Battery related parameters can be set, including battery capacity, maximum charging/ discharging power, maximum charging/ discharging current, maximum battery charging voltage, battery charging cut-off voltage, battery discharging cut-off voltage, off-grid cut-off voltage.

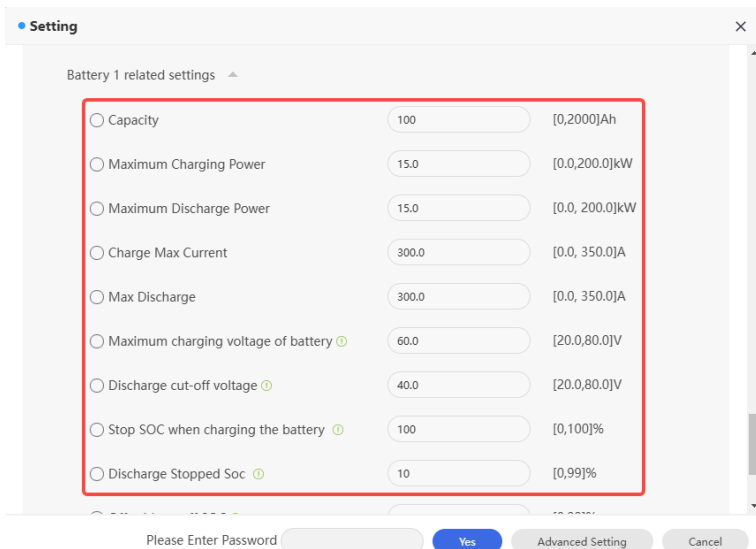

10.22) Mode switching: You can choose to switch the operating mode manually or automatically. In general, it is recommended that you select the "Auto" mode switch.

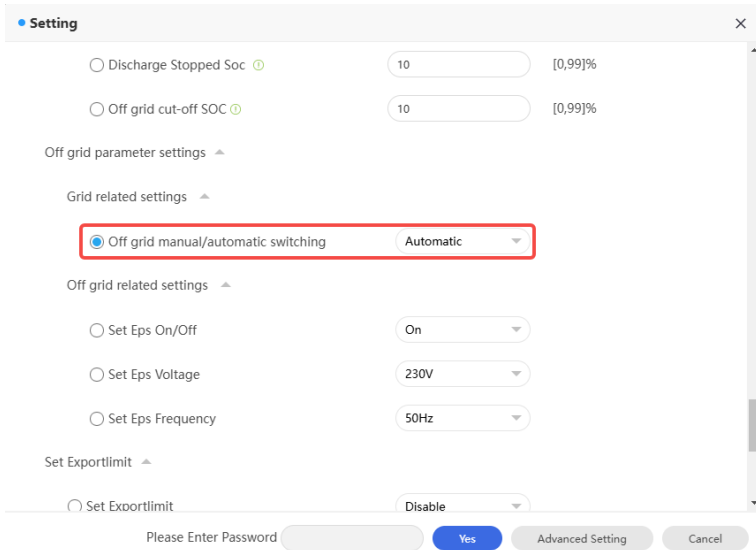

10.23) Setting off-grid enable: you can set whether or not the inverter operates in off-grid mode.

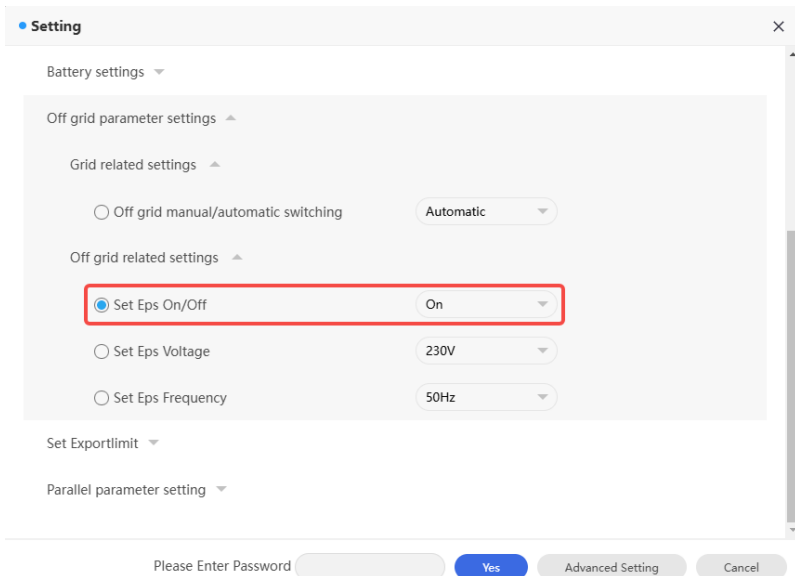

10.24) Off-grid voltage: 220V/230V can be set.

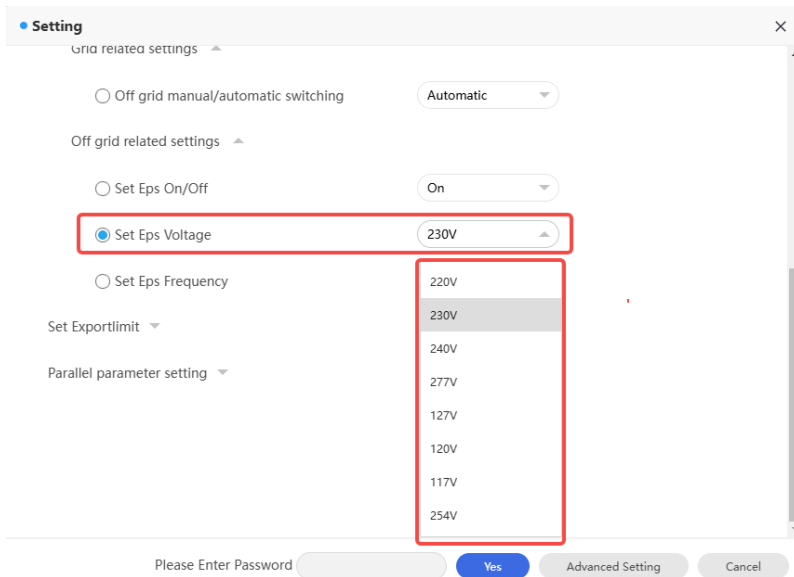

10.25) Off-grid frequency: two options: 50Hz/60Hz.

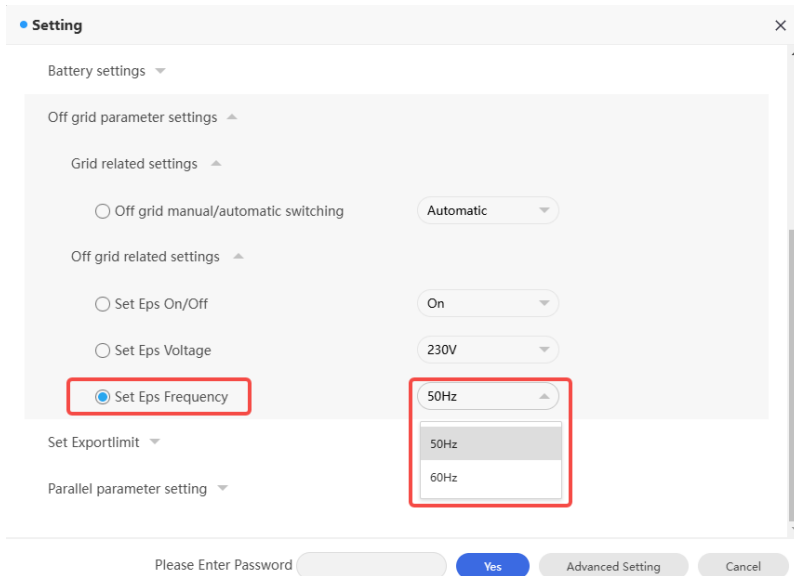

10.26) Anti-reverse flow settings: You can enable/disable the anti-reverse flow feature in accordance with applicable local regulations and set the anti-reverse flow power when the feature is enabled.

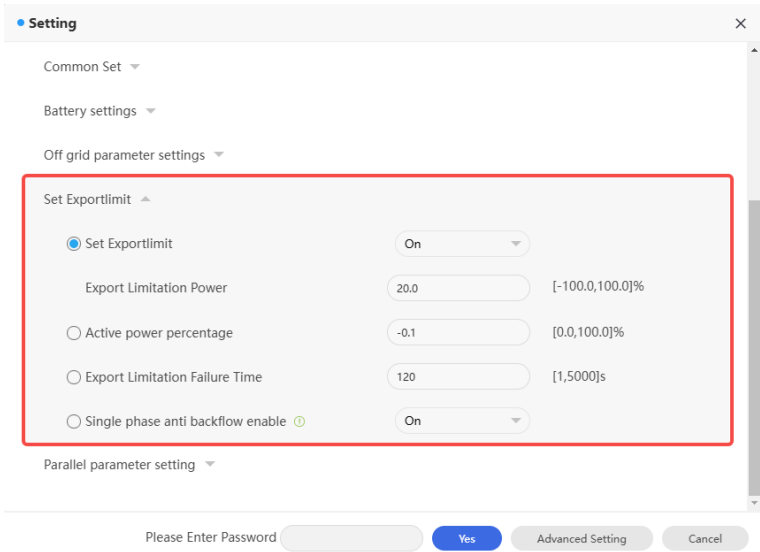

10.27) Set Parallel Enable: you can set whether to enable the parallel function or not.

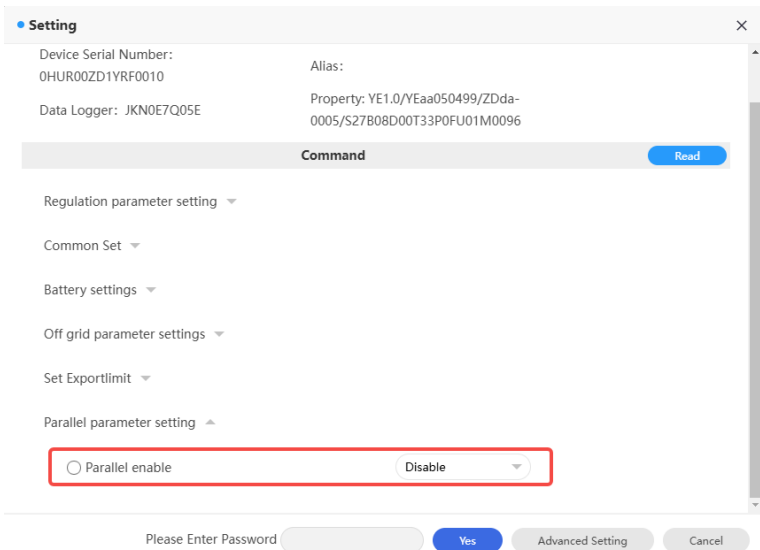

10.28) Setting the working mode and time period

Setting

Advanced Setting ▲

Maximum spontaneous self use On

Equipment mode selection and time setting ▲

Time Slot 1 **1** Load First **2** 00 : 00 ~ 00 : 00

100 % **3** Disable

Time Slot 2 Load First 00 : 00 ~ 00 : 00

100 % Disable

Time Slot 3 Load First 00 : 00 ~ 00 : 00

100 % Disable

Time Slot 4 Load First 00 : 00 ~ 00 : 00

100 % Disable

Please Enter Password Yes Advanced Setting Cancel

10.29) Disable/Enable Demand Management/Peak Shaving

Setting

100 % Disable

Demand Management/Peak Shaving ▲

Demand Management Setting Disable

Peak Shaving Backup SOC Enable Disable

Microgrid system ▼

Safety function control ▼

Register Value

Please Select Read

Start Address End Address Advanced Read

Event Record

Please Enter Password Yes Advanced Setting Cancel

10.30) GEN port access device type: can be set as generator/PV inverter/smart load.

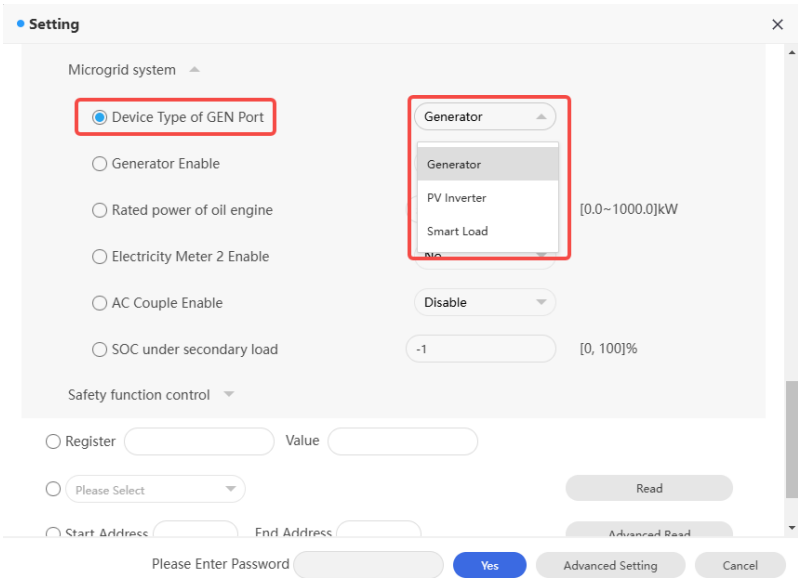

10.31) Generator Enable: Option to enable or disable the GEN.

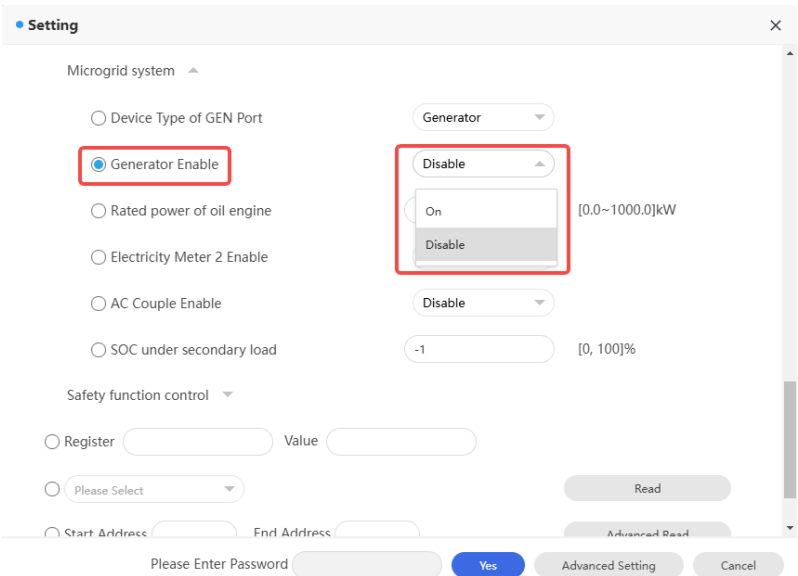

10.32) Tanker power: Tanker power can be set.

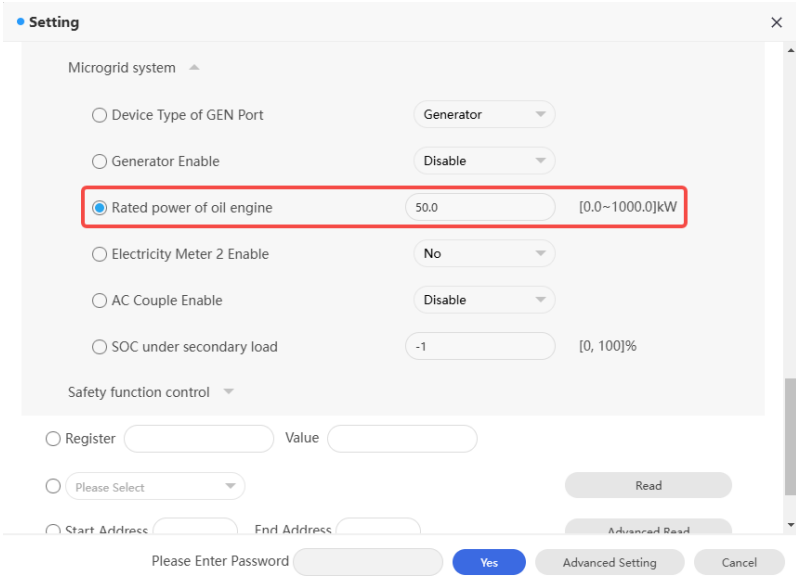

10.33) Enable/Disable Electricity Meter 2

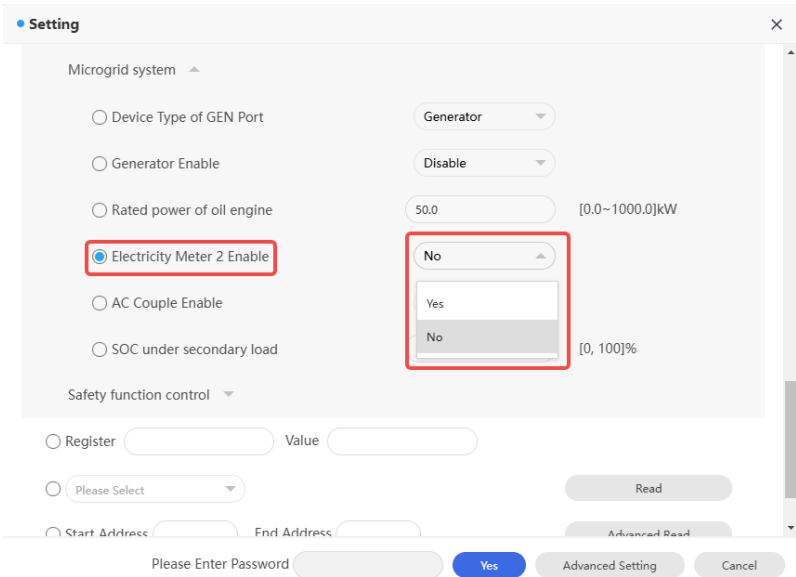

10.34) AC Couple Enable: you can set whether to enable the AC Couple function.

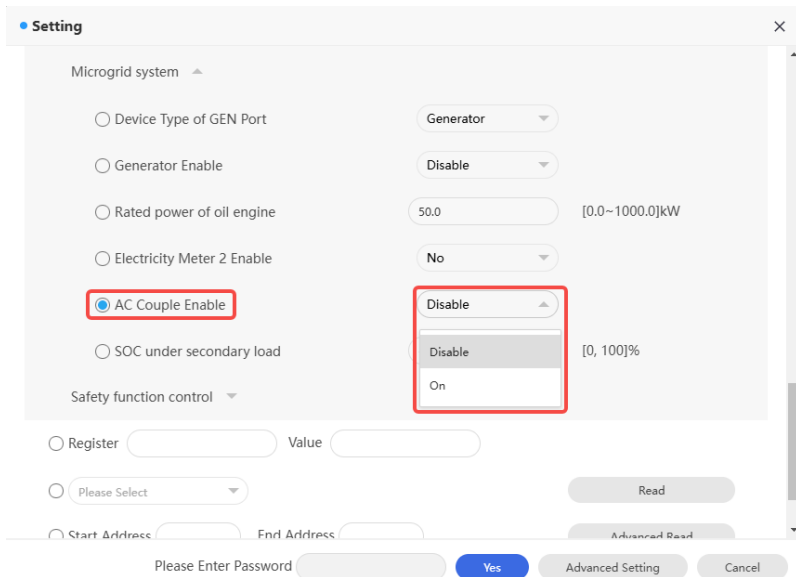

Wattmeter

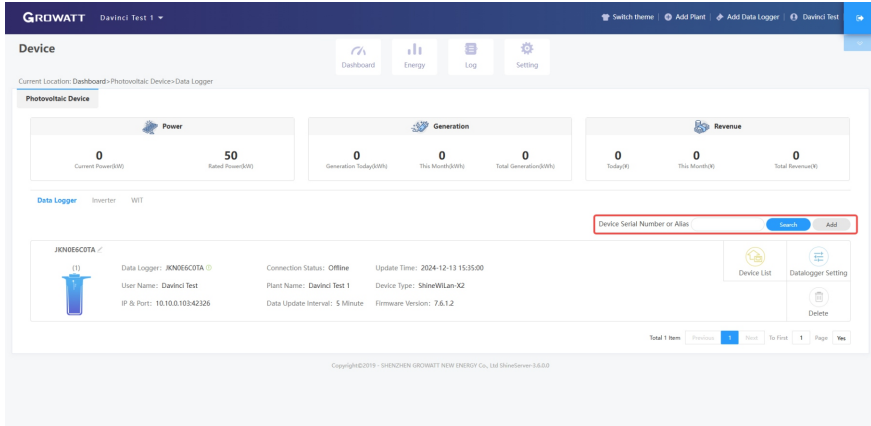

Enter the serial number of the meter or Datalogger to search for the desired meter. Once the search is complete, the type of meter, the model of the Datalogger working with the device, the status of the meter, and the serial number of the WIT inverter to which the meter is connected are displayed.

9 System Maintenance



9.1 Routine Maintenance

9.1.1 Clean the Chassis

 <p>DANGER</p>	<ul style="list-style-type: none">• Before performing any operation, disconnect the AC and DDC power supply and wait for 5 minutes after the system is powered off.• Wipe the dust off the chassis and clean the chassis with a moistened cloth.
--	---

- 1) Check periodically that the humidity is within the acceptable range and keep it away from dust;
- 2) Check the ventilation and heat dissipation of the equipment regularly. For details, see Section 9.1.2.

9.1.2 Fan Maintenance

 <p>DANGER</p>	<ul style="list-style-type: none">• Only qualified and trained electrical technicians are allowed to perform operations. Technicians must observe instructions in this manual and comply with local regulations.• Before performing any operation, disconnect all power supplies and wait for 5 minutes until the residual voltage is completely discharged.
 <p>WARNING</p>	<ul style="list-style-type: none">• Do not use the air pump to clean the fan. Otherwise, the fan may be damaged.

Ventilation and heat dissipation is essential to protect the WIT Inverter from performance de-rate due to excess heat. The fan in the WIT Inverter works to cool the components and the heat sink when the temperature is too high. Check the following possible causes and measures when an exception occurs:

- 1> The fan is stuck with foreign objects or there is dust accumulation on the heat sink; clean the fan cover, fan blades and the heat sink.
- 2> The fan is damaged and needs to be replaced.
- 3> The installation position of the WIT Inverter is not well-ventilated. Select an appropriate installation position that meets the basic installation requirements.

Cleaning and replacing the fan:

- 1> Before cleaning or replacing a fan, disconnect the DC and AC power supply and wait for at least 5 minutes.
- 2> Remove the fan fixing plate using a cross-head screwdriver, as shown in Fig 9.1:

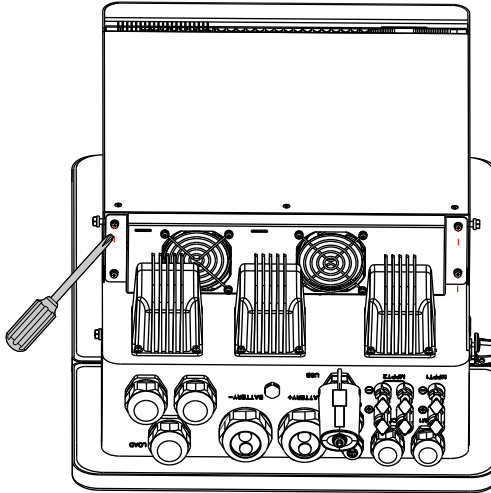

Fig 9.1

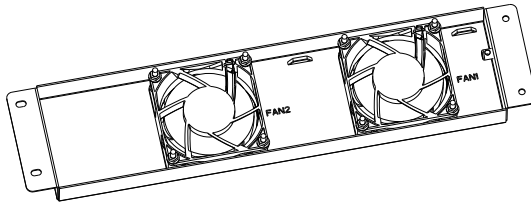



Fig 9.2 Position of the fan fixing plate

3> Disconnect the fan connector, remove the fan fixing plate with a screwdriver, and remove the fan.

4> Clean the fan cover, fan blades, and the heat sink, or replace the fan.

- (1) Use an air pump to clean the heat sink, and use a brush or wet cloth to clean the fan and its cover;
- (2) Remove the fan for cleaning if necessary;
- (3) Remove the fan that needs to be replaced using a cross-head screwdriver and install a new fan.
- (4) Bind the cables and fix them with a cabletie.
- (5) Reinstall the fan, the fan fixing plate, and the WIT inverter.

9.2 Troubleshooting

 <p>DANGER</p>	<ul style="list-style-type: none"> • It must be operated by trained and professional electrical technicians. Technicians must observe instructions in this manual and local regulations. • If the WIT Inverter reports the "PV Isolation low" alarm, do not touch the equipment as a ground fault might have occurred. • Beware of high voltages which can cause electric shocks.
--	--

9.2.1 Warning

Warnings indicate abnormal situations of WIT 4-15K-HU Hybrid Inverters, leading to a reduction in the output power. The warning sign will disappear once the fault is rectified by restarting the inverter or reconfiguring the system. The warning codes are shown in Table 9.1:

Table 9.1 Warning codes

Warning	Description	Suggestion
Warning 200	String fault	<ol style="list-style-type: none"> 1. Check if the PV panels are normal after shutdown. 2. If the error message persists, contact Growatt support.
Warning 201	PV string/PID quick-connect terminals abnormal	<ol style="list-style-type: none"> 1. Check the wiring of the string terminals after shutdown. 2. If the error message persists, contact Growatt support.
DC SPD Warning	DC SPD function abnormal	<ol style="list-style-type: none"> 1. Check the DC SPD after shutdown. 2. If the error message persists, contact Growatt support.
Warning 203	PV1 or PV2 short circuited	<ol style="list-style-type: none"> 1. Check if PV1 or PV2 is short circuited. 2. If the error message persists, contact Growatt support.
Boost Warning	PV Boost driver abnormal	<ol style="list-style-type: none"> 1. Restart the inverter. 2. If the error message persists, contact Growatt support.
AC SPD Warning	AC SPD function abnormal	<ol style="list-style-type: none"> 1. Power off the system and check the fuse. 2. If the fault persists, contact Growatt.
Warning 208	DC fuse blows	<ol style="list-style-type: none"> 1. Power off the system and check the fuse. 2. If the fault persists, contact Growatt.

Warning	Description	Suggestion
Warning 209	DC input voltage exceeds the upper threshold	<ol style="list-style-type: none"> 1. Turn off the DC switch immediately and check the DC voltage. 2. If the DC voltage is within the specified range and the error message persists, contact Growatt support.
PV Reversed	PV string is reversely connected	<ol style="list-style-type: none"> 1. Check the polarity of the PV terminals. 2. If the error message persists, contact Growatt support.
Warning 219	PID function abnormal	<ol style="list-style-type: none"> 1. Restart the inverter. 2. If the error message persists, contact Growatt support.
Warning 220	PV string disconnected	<ol style="list-style-type: none"> 1. Check if the PV string is properly connected. 2. If the error message persists, contact Growatt support.
Warning 221	PV string current unbalanced	<ol style="list-style-type: none"> 1. Check if the PV panels of the corresponding string are normal. 2. If the error message persists, contact Growatt support.
Warning 300	No utility grid connected or utility grid power failure	<ol style="list-style-type: none"> 1. Check if the grid is down. 2. If the error message persists, contact Growatt support.
Warning 301	Grid voltage is beyond the permissible range	<ol style="list-style-type: none"> 1. Check if the grid voltage is within the specified range. 2. If the error message persists, contact Growatt support.
Warning 302	Grid frequency is beyond the permissible range	<ol style="list-style-type: none"> 1. Check if the grid frequency is within the specified range. 2. If the error message persists, contact Growatt support.
Warning 303	Overload	<ol style="list-style-type: none"> 1. Please reduce the load connected to the EPS output terminal. 2. If the error message persists, contact Growatt support.
Warning 308	Meter disconnected	<ol style="list-style-type: none"> 1. Check if the meter is properly connected. 2. If the error message persists, contact Growatt support.

Warning	Description	Suggestion
Warning 309	Meter is reversely connected	<ol style="list-style-type: none"> 1. Check if the L line and the N line of the meter are reversely connected. 2. If the error message persists, contact Growatt support.
Warning 310	The voltage difference between the N line and the PE cable is abnormal	<ol style="list-style-type: none"> 1. Check if the PE cable is reliably connected after shutdown. 2. If the error message persists, contact Growatt support.
Warning 311	Phase sequence error	No operation is required. The PCS will automatically adjust the phase sequence.
Warning 400	Fan failure	<ol style="list-style-type: none"> 1. Check if the fan is properly connected after shutdown. 2. If the error message persists, contact Growatt support.
Warning 401	Meter abnormal	<ol style="list-style-type: none"> 1. Check if the meter is turned on. 2. If the meter is correctly connected to the inverter.
Warning 402	Communication between the optimizer and the inverter is abnormal	<ol style="list-style-type: none"> 1. Check if the optimizer is turned on. 2. If the optimizer is correctly connected to the inverter.
Warning 407	Over-temperature	<ol style="list-style-type: none"> 1. Restart the inverter. 2. If the error message persists, contact Growatt support.
Warning 407	overtemperature alarm	<ol style="list-style-type: none"> 1. Restart the inverter 2. If the fault message persists, contact the manufacturer
Warning 408	NTC temperature sensor is broken	<ol style="list-style-type: none"> 1. Restart the inverter. 2. If the error message persists, contact Growatt support.
Warning 411	Sync signal abnormal	<ol style="list-style-type: none"> 1. Check if the sync cable is abnormal. 2. If the error message persists, contact Growatt support.

Warning	Description	Suggestion
Warning 412	Startup requirements of grid connection are not met	<ol style="list-style-type: none"> 1. Check if the grid voltage is within the specified range and check if the grid-connection startup voltage configuration is correct. 2. Check if the PV voltage is within the specified range. 3. Restart the inverter. If the error message persists, contact Growatt support.
Warning 500	The inverter failed to communicate with the battery	<ol style="list-style-type: none"> 1. Check if the battery is turned on. 2. Check if the battery is correctly and securely connected to the inverter.
Warning 501	Battery disconnected	<ol style="list-style-type: none"> 1. Check if the battery is properly connected. 2. If the error message persists, contact Growatt support.
Warning 502	Battery voltage too high	<ol style="list-style-type: none"> 1. Check if the battery voltage is within the permissible range. 2. Check if the battery is correctly connected. 3. If the error message persists, contact Growatt support.
Warning 503	Battery voltage too low	<ol style="list-style-type: none"> 1. Check if the battery voltage is within the permissible range. 2. Check if the battery is correctly connected. 3. If the error message persists, contact Growatt support.
Warning 504	Battery terminals are reversely connected	<ol style="list-style-type: none"> 1. Check if the positive and negative terminals of the battery are reversely connected. 2. If the error message persists, contact Growatt support.
Warning 505	Temperature sensor of the lead-acid battery is disconnected	<ol style="list-style-type: none"> 1. Check if the temperature sensor of the lead-acid battery is installed or not. 2. Check if the temperature sensor is well-connected. 3. If the error message persists, contact Growatt support.

Warning	Description	Suggestion
Warning 506	Battery temperature is out of range	<ol style="list-style-type: none"> 1. Check if the ambient temperature of the battery is within the specified range. 2. If the error message persists, contact Growatt support.
Warning 507	BMS reported a fault; both charging and discharging failed	<ol style="list-style-type: none"> 1. Figure out the cause according to the BMS error code. 2. If the error message persists, contact Growatt support.
Warning 508	Lithium battery overload protection	<ol style="list-style-type: none"> 1. Check if the power of the load exceeds the BAT rated discharge power. 2. If the error message persists, contact Growatt support.
Warning 509	BMS communication abnormal	<ol style="list-style-type: none"> 1. Restart the inverter. 2. If the error message persists, contact Growatt support.
Warning 510	BAT SPD function abnormal	<ol style="list-style-type: none"> 1. Check the BAT SPD after powering off the device. 2. If the error message persists, contact Growatt support.
Warning 600	Output DC component bias abnormality	<ol style="list-style-type: none"> 1. Restart the inverter 2. If the fault message persists, contact the manufacturer
Warning 601	DC component over high in output voltage	<ol style="list-style-type: none"> 1. Restart the inverter. 2. If the error message persists, contact Growatt support.
Warning 602	Off-grid output voltage too low	<ol style="list-style-type: none"> 1. Restart the inverter 2. If the fault message persists, contact the manufacturer
Warning 603	Off-grid output voltage too high	<ol style="list-style-type: none"> 1. Restart the inverter 2. If the fault message persists, contact the manufacturer
Warning 604	Off-grid output current overcurrent	<ol style="list-style-type: none"> 1. Detect whether the load is out of specification 2. Restart the inverter, if the fault message still exists, contact the manufacturer

Warning	Description	Suggestion
Warning 605	Off-grid bus voltage too low	<ol style="list-style-type: none"> 1. Check if the load power exceeds the upper limit. 2. Restart the inverter. If the error message persists, contact Growatt support.
Warning 606	Off-grid output overload	<ol style="list-style-type: none"> 1. Detect whether the load is out of specification 2. Restart the inverter, if the fault message still exists, contact the manufacturer
Warning 609	Balanced circuit abnormal	<ol style="list-style-type: none"> 1. Restart the inverter. 2. If the error message persists, contact Growatt support.

9.2.2 Error

The error code indicates that the device is damaged or the configurations are abnormal. Only qualified and trained electrical technicians are allowed to rectify the faults. The error message will disappear after the fault is rectified. If the problem persists, please contact Growatt.

Table 9.2 Error codes

Error Code	Description	Suggestion
AFCI Fault	An arc fault has been detected	<ol style="list-style-type: none"> 1. After shutdown, check the connection of the PV string. 2. Restart the inverter. 3. If the error message persists, please contact Growatt support.
GFCI High	An excessively high leakage current has been detected	<ol style="list-style-type: none"> 1. Restart the inverter. 2. If the error message persists, please contact Growatt support.
PV Voltage High	DC input voltage exceeds the upper threshold	<ol style="list-style-type: none"> 1. Disconnect the DC switch immediately and check the voltage. 2. If the DC input voltage is within the permissible range and the error message persists, please contact Growatt support.

Error Code	Description	Suggestion
PV Isolation Low	PV panels have low insulation resistance	<ol style="list-style-type: none"> 1. Check if the PV strings are properly grounded. 2. If the error message persists, please contact Growatt support.
PV Reversed	PV string reversely connected	<ol style="list-style-type: none"> 1. After shutdown, check if the PV string is reversely connected to the inverter. 2. Restart the inverter. 3. If the error message persists, please contact Growatt support.
AC V Outrange	Grid voltage is beyond the permissible range	<ol style="list-style-type: none"> 1. Check the grid voltage. 2. If the grid voltage is within the permissible range and the error message persists, please contact Growatt support.
No AC	No utility grid connected or utility grid power failure	<ol style="list-style-type: none"> 1. After shutdown, check the AC wiring. 2. If the error message persists, please contact Growatt support.
PE Abnormal	The voltage difference between the N line and the PE cable is abnormal	<ol style="list-style-type: none"> 1. After shutdown, check if the ground cable is reliably connected. 2. If the error message persists, please contact Growatt support.
AC F Outrange	Grid frequency is beyond the permissible range	<ol style="list-style-type: none"> 1. Check the grid frequency and restart the inverter. 2. If the error message persists, please contact Growatt support.
Error 309	Grid ROCOF (Rated of Change of Frequency) abnormal	<ol style="list-style-type: none"> 1. Check the grid frequency and restart the inverter. 2. If the error message persists, please contact Growatt support.
NE Fault	Neutral-to-Ground voltage is too low	<ol style="list-style-type: none"> 1. Check whether the N line on the inverter side with PV negative grounding is short-circuited with the ground cable and whether the output side is isolated with a transformer. 2. If the error message persists, please contact Growatt support.
Error 311	Export limitation fail-safe	<ol style="list-style-type: none"> 1. After shutdown, check the connection of the CT and the meter. 2. If the error message persists, please contact Growatt support.

Error Code	Description	Suggestion
Error 400	DCI bias abnormal	1. Restart the inverter. 2. If the error message persists, contact Growatt support.
Error 402	High DC component in output current	1. Restart the inverter. 2. If the error message persists, contact Growatt support.
Error 404	Bus voltage sampling abnormal	1. Restart the inverter. 2. If the error message persists, please contact Growatt support.
Error 405	Relay fault	1. Restart the inverter. 2. If the error message persists, please contact Growatt support.
Error 408	Over-temperature	1. After shutdown, check the temperature of the inverter and restart the inverter after the temperature is within the acceptable range. 2. If the error message persists, please contact Growatt support.
Error 409	Bus voltage abnormal	1. Restart the inverter. 2. If the error message persists, please contact Growatt support.
Error 411	Internal communication failure	1. Check the wiring of the communication board after shutdown. 2. If the error message persists, please contact Growatt support.
Error 412	Temperature sensor disconnected	1. Check the wiring of the communication board after shutdown. 2. If the error message persists, please contact Growatt support.
Error 413	IGBT drive fault	1. Restart the inverter. 2. If the error message persists, please contact Growatt support.
Error 414	EEPROM error	1. Restart the inverter. 2. If the error message persists, please contact Growatt support.
Error 415	Auxiliary power supply abnormal	1. Restart the inverter. 2. If the error message persists, please contact Growatt support.
Error 416	DC/AC overcurrent protection	1. Restart the inverter. 2. If the error message persists, please contact Growatt support.

Error Code	Description	Suggestion
Error 417	Communication protocol mismatch	1. Restart the inverter. 2. If the error message persists, please contact Growatt support.
Error 418	DSP and COM firmware version mismatch	1. Restart the inverter. 2. If the error message persists, please contact Growatt support.
Error 419	DSP software and hardware version mismatch	1. Restart the inverter. 2. If the error message persists, please contact Growatt support.
Error 421	CPLD abnormal	1. Restart the inverter. 2. If the error message persists, please contact Growatt support.
Error 422	Redundancy sampling inconsistent	1. Restart the inverter. 2. If the error message persists, please contact Growatt support
Error 423	PWM pass-through signal failure	1. Restart the inverter. 2. If the error message persists, please contact Growatt support.
Error 425	AFCI self-test failure	1. Restart the inverter. 2. If the error message persists, please contact Growatt support.
Error 426	PV current sampling abnormal	1. Restart the inverter. 2. If the error message persists, please contact Growatt support.
Error 427	AC current sampling abnormal	1. Restart the inverter. 2. If the error message persists, please contact Growatt support.
Error 429	BUS softboot failure	1. Restart the inverter. 2. If the error message persists, please contact Growatt support.
Error 430	EPO fault	1. Restart the inverter. 2. If the error message persists, please contact Growatt support.
Error 431	Monitoring chip BOOT verification failed	1. Restart the inverter. 2. If the error message persists, please contact Growatt support.

Error Code	Description	Suggestion
Error 500	BMS failed to communicate with the inverter	<ol style="list-style-type: none"> 1. Check the connection of the RS485 cable between the inverter and the battery. 2. Check if the battery is in the sleep mode. 3. If the error message persists, please contact Growatt support.
Error 501	The BMS reports that the battery failed to charge/discharge	<ol style="list-style-type: none"> 1. Figure out the fault based on the BMS error code. 2. If the error message persists, please contact Growatt support.
Bat Voltage Low	The battery voltage is below the lower threshold	<ol style="list-style-type: none"> 1. Check the battery voltage. 2. If the error message persists, please contact Growatt support.
Error 503	The battery voltage exceeds upper threshold	<ol style="list-style-type: none"> 1. Check the battery voltage. If it is within the permissible range, please restart the inverter. If not, please replace the battery. 2. If the error message persists, please contact Growatt support.
Error 504	The battery temperature is beyond the range for charging / discharging	<ol style="list-style-type: none"> 1. Check the temperature of the battery. 2. If the error message persists, please contact Growatt support.
Bat Reversed	Battery terminals reversed	<ol style="list-style-type: none"> 1. Check if the battery terminals are reversely connected. 2. If the error message persists, please contact Growatt support.
Error 506	Battery open-circuited	<ol style="list-style-type: none"> 1. Check the wiring of the battery terminals. 2. If the error message persists, please contact Growatt support.
Error 507	Battery overload protection	<ol style="list-style-type: none"> 1. Check if the power of the load exceeds the battery rated discharge power. 2. If the error message persists, please contact Growatt support.
Error 508	BUS2 Volt Abnormal	<ol style="list-style-type: none"> 1. Restart the inverter. 2. If the error message persists, please contact Growatt support.

Error Code	Description	Suggestion
Error 509	BAT Charge OCP (Overcurrent Protection)	1. Check if the PV voltage is oversized. 2. If the error message persists, please contact Growatt support.
Error 510	BAT Discharge OCP (Overcurrent Protection)	1. Check if the battery discharge current configuration is proper. 2. If the error message persists, please contact Growatt support.
Error 511	BAT soft start failed	1. Restart the inverter. 2. If the error message persists, please contact Growatt support.
EPS Output Short	Off-grid output short-circuited	1. Restart the inverter. 2. If the error message persists, please contact Growatt support.
Error 601	Off-grid BUS Volt Low	1. Check if the battery is working properly or the battery experiences capacity loss. 2. If the error message persists, please contact Growatt support.
Error 602	Abnormal Volt at the off-grid terminal	1. Check if a voltage is present at the AC port. 2. If the error message persists, please contact Growatt support.
Error 603	Soft start failed	1. Restart the inverter. 2. If the error message persists, please contact Growatt support.
Error 604	Off-grid output voltage abnormal	1. Restart the inverter. 2. If the error message persists, please contact Growatt support.
Error 605	Balanced circuit self-test failed	1. Restart the inverter. 2. If the error message persists, please contact Growatt support.
Error 606	High DC component in output voltage	1. Restart the inverter. 2. If the error message persists, please contact Growatt support.
OverLoad	Off-grid output overload	1. Restart the inverter. 2. If the error message persists, please contact Growatt support.
Error 608	Off-grid parallel signal abnormal	1. Check if the communication cables are properly connected. 2. If the error message persists, please contact Growatt support.

Product Specifications 10

Table 10.1 WIT 4/5/6/8/10/12/15K-HU Specifications

Model Specifications	WIT 4K-HU	WIT 5K-HU	WIT 6K-HU	WIT 8K-HU	WIT 10K-HU	WIT 12K-HU	WIT 15K-HU
Input data(PV)							
Max. recommended PV power(for module STC)	6.4kW	8kW	9.6kW	12.8kW	16kW	19.2kW	24kW
Max. DC voltage	1000V						
Start voltage	180V						
Nominal voltage	600V						
MPP voltage range	150V-850V						
Full Load DC Voltage Range	200V-750V	200V-750V	240V-750V	320V-750V	400V-750V	320V-750V	400V-750V
No. of MPP trackers	1			2			
No. of PV strings per MPP tracker	2			1+1		2+1	
Max. input current per MPP tracker	40A			20A+20A		40A+20A	
Max. short-circuit current per MPP tracker	50A			25A/25A		50A/25A	
Battery data (DC)							
Battery voltage range	40-60V						
Full load battery voltage range	40-60V	42-60V	42-60V	42.6-60V	48.4-60V	51.6-60V	55-60V
Recommended battery voltage	51.2V						
No. of battery input	1						
Max. charging / discharging current	110A	125A	150A	200A	220A	250A	290A
BMS communication	RS485/CAN						
AC Input/Output (GRID)							
AC input/output nominal power	8kW/ 4kW	10kW/ 5kW	12kW/ 6kW	16kW/ 8kW	20kW/ 10kW	24kW/ 12kW	30kW/ 15kW
Max. AC input/output apparent power	8.8kVA /4.4kVA	11kVA /5.5kVA	13.2kVA/ 6.6kVA	17.6kVA/ 8.8kVA	22kVA/ 11kVA	26.4kVA/ 13.2kVA	33kVA/ 16.5kVA

Model Specifications	WIT 4K-HU	WIT 5K-HU	WIT 6K-HU	WIT 8K-HU	WIT 10K-HU	WIT 12K-HU	WIT 15K-HU
Nominal AC voltage/range	220V/230V L-N, 380V/400V L-L, -15% ~ 10%						
Nominal AC grid frequency/range	45~55 Hz/55~65 Hz						
Max. input/output current	13.4A/ 6.7A@ 220V	16.7A/ 8.4A@ 220V	20.0A/ 10.0A@ 220V	26.6A/ 13.3A@ 220V	33.3A/ 16.7A@ 220V	40A/ 20A@ 220V	50.1A/ 25A@ 220V
Max. Continuous AC Passthrough	50.1A						
Power factor (@nominal power)	>0.99						
Adjustable power factor	-1...+1						
THDi	<3 per cent						
AC grid connection type	3P3W+PE/3P4W+PE						
Input/Output Generator (GEN)							
AC nominal power	8kW	10kW	16kW	16kW	20kW	24kW	30kW
Max. input current(GEN/AC Couple)	12.2A/ 11.6A	15.2A/ 14.4A	18.2A/ 17.4A	24.2A/ 23.2A	30.4A/ 29A	36.4A/ 34.8A	45.4A/ 43.4A
Max.Continuous AC Passthrough	50.1A						
Nominal AC voltage	220V/230V L-N, 380V/400V L-L						
Nominal AC grid frequency	50Hz/60Hz						
AC connection type	3P3W+PE/3P4W+PE						
Stand alone(Back up)							
AC nominal output power	4kW	5kW	6kW	8kW	10kW	12kW	15kW
Max. AC apparent power	4kW	5kW	6kW	8kW	10kW	12kW	15kW
Nominal AC voltage	220V/230V(L-N) 380V/400V(L-L)						
Nominal AC frequency	50/60HZ						
Max. output current	12.2A	15.2A	18.2A	24.2A	30.2A	36.4A	45.5A

Model Specifications	WIT 4K-HU	WIT 5K-HU	WIT 6K-HU	WIT 8K-HU	WIT 10K-HU	WIT 12K-HU	WIT 15K-HU
Overload Capability	2x rated power, 10 S						
THDv	<3% (Linear full load)						
Switch time	≤10ms						
Efficiency							
Max. efficiency	97.60%						
European efficiency	97.00%						
MPPT efficiency	99.90 %						
Protection devices							
DC reverse polarity protection	adjuvant						
Battery reverse protection	adjuvant						
Insulation resistance monitoring	adjuvant						
AC/DC surge protection	Type II						
AC short-circuit protection	adjuvant						
Ground fault monitoring	adjuvant						
Grid monitoring	adjuvant						
String monitoring	adjuvant						
Anti-islanding protection	adjuvant						
Residual-current monitoring unit	adjuvant						
PID function	selectable						
AFCI protection	selectable						
General data							
Dimensions (W / H / D)	475/698/240mm						
Weight	43kg						
Operating temperature range	-30°C - 60°C (>45°C, derated)						

Model	WIT	WIT	WIT	WIT	WIT	WIT	WIT
Specifications	4K-HU	5K-HU	6K-HU	8K-HU	10K-HU	12K-HU	15K-HU
Noise emission (typical)	≤50dB						
Altitude	3000m						
Topology	Transformerless						
Cooling	Smart air cooling						
Protection degree	IP66						
Relative humidity	0~95%						
PV connection	MC2						
AC connection	Cable glands +terminals						
Battery connection	OT terminal						
Interfaces							
Display	OLED+LED/APP						
RS485/CAN/USB	RS485/CAN/USB						
WIFI/4G/LAN	WIFI/LAN						
Warranty: 5 / 10 years	Yes/Opt.						
Certificates and approvals							
Grid regulation	IEC 61727, IEC 62116, IEC 61683, IEC 60068, EN 50549-10/1, VDE 4105, NC RfG						
EMC	IEC/EN 61000-6-1/2/3/4, EN 55011, EN 62920						
Safety	IEC/EN62109-1, IEC/EN62109-2						

Decommissioning the WIT 11 Inverter

Handle the WIT Inverter that will not be operated in the future properly.

- 1> Disconnect the external AC circuit breaker and prevent accidental reconnection due to improper operation.
- 2> Set the DC switches to the OFF position.
- 3> Disconnect the battery side switch.
- 4> Disconnect the upstream battery circuit breaker..
- 5> Wait at least 5 minutes before performing operations on it..
- 6> Disconnect the AC output power cables.
- 7> Disconnect the DC input power cables.
- 8> Remove the inverter from the bracket.
- 9> Dispose of the inverter according to local disposal rules.

12 Warranty

Growatt guarantees maintenance and replacement of the defective product under warranty.

12.1 Conditions

1. Growatt will ask users to provide product information by filling a form before making warranty repairs, including the date of purchase and installation, the serial number of the WIT Inverter, fault description and other information.
2. The defected product shall be returned to Growatt for recycling and disposal.

12.2 Disclaimer

Growatt shall not be liable for any consequences of the following circumstances:

1. Unauthorized removal of the product, such as removing the tamper-proof label and the upper cover of the WIT Inverter.
 2. Damage caused during transportation.
 3. Improper operations during installation and commissioning.
 4. Failure to observe the operation instructions regarding the installation, operation and storage of the WIT Inverter.
 5. Unauthorized modifications or improper maintenance on the WIT Inverter.
 6. Improper use and operation.
 7. Damage caused by storage conditions that do not meet the requirements specified in this manual.
 8. Failure to follow the safety precautions and applicable laws and regulations due to customer's negligence.
 9. Damage due to force majeure, such as lightning, floods, storms, fire.
 10. Power off the PCS before upgrading the firmware; otherwise it will shut down automatically during the upgrade process and supply no power to the loads.
- In the event of a product malfunction or failure caused by the circumstance mentioned above, Growatt can provide paid maintenance services after conducting a fault diagnosis if required.

Contact Us 13

If you have technical problems with our products, please contact Growatt for technical support. To provide you with the necessary assistance, please have the following information ready:

1. Model number of the WIT Inverter
2. Serial number of the WIT Inverte
3. Error code of the WIT Inverter
4. Information indicated on the LED display
5. DC input voltage and AC output voltage of the WIT Inverter
6. Communication method of the WIT Inverter

Shenzhen Growatt New Energy Co., Ltd.

4-13/F, Building A, Sino-German (Europe) Industrial Park,
Hangcheng Blvd, Bao'an District, Shenzhen, China

E service@growatt.com

W en.growatt.com

For local customer support, please visit <https://en.growatt.com/support/contact>



Download
Manual



 Growatt New Energy

Shenzhen Growatt New Energy Co., Ltd.

4-13/F, Building A, Sino-German (Europe) Industrial Park,
Hangcheng Blvd, Bao'an District, Shenzhen, China

E service@growatt.com

W en.growatt.com

For local customer support, please visit <https://en.growatt.com/support/contact>

GR-UM-476-A-00 (PN: 044.0140400)